



Focus **Falls**

# PREVENTING SLIPS/FALLS AND LOSS OF BALANCE

## IN INDUSTRIAL WORKPLACES



**IAPA**

It's About Making A Difference.

© INDUSTRIAL ACCIDENT PREVENTION ASSOCIATION, 2007. All rights reserved.

As part of IAPA's mission to inform and educate, IAPA permits users to reproduce this material for their own internal training and educational purposes only. For any other purpose, including use in conjunction with fee for service or other commercial activities, no part of this material may be used, reproduced, stored in a retrieval system, or transmitted in any form or by any means, electronic, mechanical, photocopy, recorded, or otherwise, without the express prior written permission of the Industrial Accident Prevention Association.

The information contained in this material is provided voluntarily as a public service. No warranty, guarantee or representation is made by IAPA as to the correctness, suitability, fitness, or sufficiency of any information contained in this material. Use of this material means that the user agrees that IAPA and its employees will not have and are released from any liability whatsoever, however caused or arising, in connection therewith. Users also acknowledge that it cannot be assumed that all acceptable safety measures are contained in this material or that additional measures may not be required in the conditions or circumstances that are applicable to the user or his/her organization, and that the user will personally make his/her own assessment of the information contained in this material.

While IAPA does not undertake to provide a revision service or guarantee accuracy, we shall be pleased to respond to your individual requests for information.

# Table of Contents

- 1. Introduction .....4**
- 2. Hazard Control Overview.....5**
- 3. Slips/Falls and Loss of Balance Hazard Assessment .....6**
  - 3a. Sample: Slips/Falls Hazard Assessment Checklist.....9
- 4. Sample Slips/Falls and Loss of Balance (from heights) Standard Operating Procedure (SOP) .....16**
- 5. Sample Slips/Falls and Loss of Balance (same elevation) Standard Operating Procedure (SOP) .....21**
- 6. Hazard Control Information – Slips/Falls and Loss of Balance (from same elevation and heights).....25**
  - 6a. General Best Practices .....25
  - 6b. Fall Protection Systems .....27
  - 6c. Equipment – Working from Heights .....31
  - 6d. Slippery Surface – Controlling Hazards at the Source .....36
  - 6e. Co-efficient of Friction Hazards and Controls .....37
  - 6f. Trip Hazards – Control Through Design.....38
  - 6g. Trip Hazards – Control Through Programs and Systems .....39
  - 6h. Slips/Trips Hazards – Control Through Warning Systems .....40
  - 6i. Walking Surfaces – General Controls .....45
- 7. Hazard Information – Ministry of Labour Bulletins .....46**
  - 7a. MOL Engineering Data Sheet 2-04: Fixed Access Ladders.....47
  - 7b. MOL Engineering Data Sheet 2-05: Railings and Toeboards .....55
- 8. Resources .....56**
- 9. References.....57**

# 1. Introduction

Anyone can slip/fall or lose their balance at work (hereto referred to as slips/falls). In Ontario, 80 people are injured everyday in a fall at work; that's one every twenty minutes.

## **Why Pay Attention to Slips/Falls and Loss of Balance Hazards in the Workplace?**

- ▶ “Same level falls”, like slips and trips, account for 65% of fall injuries
- ▶ Falls from heights account for almost 34% of falls (and most of the fall related deaths)
- ▶ Each person injured in a fall is away from work an average of six weeks
- ▶ Over 18,000 injuries a year at 10,000 Ontario workplaces are due to slips and falls
- ▶ One in every six lost-time injuries in Ontario is caused by a fall

Source: WSIB 2003:2004 (for specific references, please refer to reference section)

## **What Conditions or Factors Cause People to Slip/Fall and/or Lose their Balance?**

- ▶ Poor lighting, slippery surfaces, inadequate housekeeping and other such deficient working conditions
- ▶ Missing protective devices (e.g., guardrails)
- ▶ Misused equipment or equipment in poor condition (e.g., ladders and scaffolds)
- ▶ Lack of appropriate personal protective equipment (e.g., equipment is not available, not used, or misused)
- ▶ Poor work practices (e.g., unclear job procedures, lack of training, or workers rushing to meet deadlines)

## **What Can You Do?**

This information has been prepared to give you information and guidance in identifying and controlling slip/fall and loss of balance hazards in your workplace. It also lists many resources that can help you develop and implement a slip/fall and loss of balance prevention program.

## 2. Hazard Control Overview

### Control Sites

Controlling a hazard means eliminating the hazard or reducing it to a level that protects workers from its adverse effects. Priority for controlling hazards will start with controls at the **source**. If unable to control at the source, controls along the path from the source to the worker will be implemented. When no other means of control can be identified controls at the worker will be used.

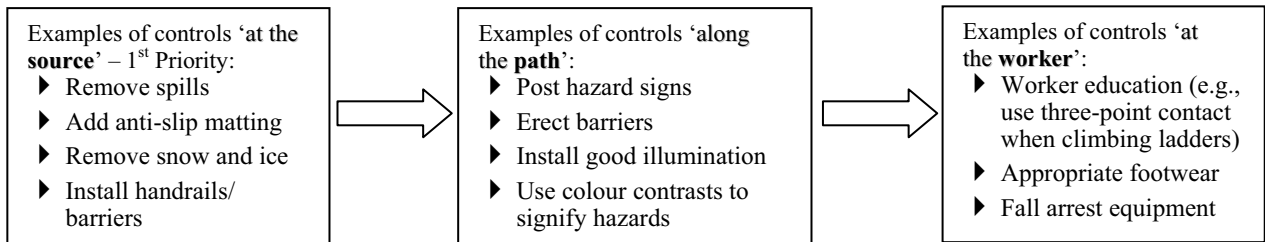

### Assessing Hazards

To put measures in place that will eliminate a risk or reduce it to a level that protects workers it is important to assess risk, giving consideration to all three sites (source, path and worker).

## 3. Slips/Falls and Loss of Balance Hazard Assessment

### **Purpose**

The purpose of a Slips/Falls (and Loss of Balance) Hazard Assessment is to identify and reduce loss through a systematic evaluation of the physical conditions of workplace, property and work activities.

The Hazard Assessment is a crucial first step in implementing or improving a Slips/Falls Standard Operating Procedure (SOP), or program.

### **Scope**

A Slips/Falls Hazard Assessment should assess all aspects of the workplace associated with the potential for slips and falls by workplace parties.

### **Responsibilities**

**Senior management** is responsible for:

- ▶ developing and selecting a Slips/Falls Hazard Assessment Team;
- ▶ enabling the appropriate knowledge and skill development of the Assessment Team members;
- ▶ reviewing and implementing appropriate recommendations derived from the Slips/Falls Hazard Assessment (incorporated into a Slips/Falls Control Program); and
- ▶ analyzing and assessing the Slips/Falls Control Program.

The **Slips/Falls Hazard Assessment Team\* (or JHSC)** is responsible for:

- ▶ reviewing non-compliance reports, and accident and inspection reports to identify slips/fall occurrences and locations;
- ▶ conducting Slips/Falls Hazard Assessments according to the team objectives;
- ▶ developing Slips/Falls Hazard prevention recommendations; and
- ▶ providing copies of completed Hazard Assessments and recommendations to the Safety Coordinator.

\*Note: Members of the Joint Health and Safety Committee may be the same members that make up the Slips/Falls Hazard Assessment Team.

The **Health and Safety Coordinator** is responsible for:

- ▶ implementing a learning needs assessment to identify training needs that must be addressed amongst the members of the Hazard Assessment team;
- ▶ reviewing the completed Hazard Assessment Checklists to confirm that all areas of the workplace have been analyzed according to the procedures; and
- ▶ providing copies of completed Hazard Assessments and recommendations to senior management for review and further action.

#### **Frequency**

A Slips/Falls Hazard Assessment should be conducted:

- ▶ annually;
- ▶ following an accident involving slips or falls; and/or
- ▶ when the physical conditions or practices within the department have been modified.

The results of the assessments should be reviewed by senior management who is responsible for ensuring that the Slips/Falls Control program is appropriately maintained to minimize the risk of slips and falls.

#### **Procedure**

The Hazard Assessment team will develop a Slips/Falls Hazard Assessment Checklist which they will use to conduct Hazard Assessments as required. Pages 9-15 include a sample Slips/Falls Hazard Assessment Checklist.

Upon completion of the Assessment, to aid in the development of recommendations regarding controls for the identified risks, the Hazard Assessment team will use the enclosed:

- ▶ Sample: Slips/Falls and Loss of Balance (from heights) Standard Operating Procedure;
- ▶ Sample: Slips/Falls and Loss of Balance (same elevation) Standard Operating Procedure;
- ▶ Hazard Control Information;
- ▶ Case Studies;
- ▶ Hazard Information (Ministry of Labour Bulletins); and
- ▶ Resources list.

### 3. Slips/Falls and Loss of Balance Hazard Assessment

---

The Hazard Assessment may also want to, where appropriate, refer to the Construction Projects Regulation for additional information on fall protection.

Senior management will review the results, recommendations and Control Program with the Safety Coordinator, Joint Health and Safety Committee, and Slips/Falls Hazard Assessment Team. Senior management will be responsible for the final decisions (pertaining to recommendations) and subsequent implementation of appropriate controls.

#### **Internal Communication**

The Slips/Falls Hazard Assessment and Control Program will be communicated.

- ▶ to all employees through the general notice system; and
- ▶ through departmental notification prior to the team assessments in each department.

The health and safety manual must contain the organization's current slips/falls assessment policies and procedures, and be available for distribution to employees as needed.

#### **Training**

All Slips/Falls Hazard Assessment team members require knowledge pertaining to:

- ▶ the respective Slips/Falls Hazard Assessment procedures
- ▶ the Slips/Falls Hazard Control Program
- ▶ technical factors related slips, trips and falls (e.g., dynamics of a fall, understanding the principles of co-efficient of friction, etc.)
- ▶ hazard identification
- ▶ causal analysis and statistical analysis
- ▶ report writing (and, if required, data entry)

The Safety Coordinator will conduct a learning needs analysis (with all Slips/Falls Hazard Assessment Team members) to identify gaps in knowledge or skills. Based on the gaps identified, specific training will be provided. Training may be provided internally or supplemented externally as needed.



### 3. Slips/Falls and Loss of Balance Hazard Assessment

#### 3a. Sample: Slips/Falls Hazard Assessment Checklist

\*Note: The checklist should be modified to add/remove conditions and areas to ensure workplace specific needs are being addressed in the assessment.

Date: \_\_\_\_\_ Names of those completing the checklist: \_\_\_\_\_  
 \_\_\_\_\_  
 \_\_\_\_\_

#### Part A. Work Areas

Conditions	Check (√) if condition exists		Description of Controls 'at the source'	Description of Controls 'along the path'	Description of Controls 'at the worker'	Check if Additional Controls Recommended
		<input type="checkbox"/>				
<b>Work Areas/ Conditions Associated with:</b>	Loading Docks	<input type="checkbox"/>				<input type="checkbox"/>
	Balconies	<input type="checkbox"/>				<input type="checkbox"/>
	Galleries	<input type="checkbox"/>				<input type="checkbox"/>
	Landings	<input type="checkbox"/>				<input type="checkbox"/>
	Platforms	<input type="checkbox"/>				<input type="checkbox"/>
	Stairs	<input type="checkbox"/>				<input type="checkbox"/>

### 3. Slips/Falls and Loss of Balance Hazard Assessment

Conditions	Check (√) if condition exists		Description of Controls 'at the source'	Description of Controls 'along the path'	Description of Controls 'at the worker'	Check if Additional Controls Recommended
		<input type="checkbox"/>				
	Walkways	<input type="checkbox"/>				<input type="checkbox"/>
	Mezzanines	<input type="checkbox"/>				<input type="checkbox"/>
	Parking Areas	<input type="checkbox"/>				<input type="checkbox"/>
	Sidewalks	<input type="checkbox"/>				<input type="checkbox"/>
	Openings in Floors	<input type="checkbox"/>				<input type="checkbox"/>
	Openings in Roof	<input type="checkbox"/>				<input type="checkbox"/>

Comments Regarding Controls Pertaining to Work Areas:

### 3. Slips/Falls and Loss of Balance Hazard Assessment

---

#### Part B. Housekeeping

	Check (√) if Condition is Present		Process Currently Implemented to Prevent/Control Condition	Notes Regarding Recommended Changes
<b>Housekeeping:</b>	Cluttered Floors	<input type="checkbox"/>		
	Tripping Hazards	<input type="checkbox"/>		
	Slipping Hazards	<input type="checkbox"/>		
	Poor Drainage	<input type="checkbox"/>		
	Inappropriate Material Storage	<input type="checkbox"/>		
	Cluttered or Congested Aisles	<input type="checkbox"/>		
	Unidentified Waste Areas	<input type="checkbox"/>		

### 3. Slips/Falls and Loss of Balance Hazard Assessment

#### Part C. Lighting

	Describe Lighting	Notes Regarding Recommendations
Lighting Condition at Floor Level		
Lighting Condition for working at Heights		

#### Part D. Surface Conditions

	Check (✓) if Condition is Present	Process Currently Implemented to Prevent and/or Control Condition	Notes Regarding Recommended Changes
<b>Working Surface Conditions with:</b>	Oil, Grease, Wax <input type="checkbox"/>		
	Fluids <input type="checkbox"/>		
	Ice/Snow <input type="checkbox"/>		
	Irregular Surfaces <input type="checkbox"/>		
<b>Uneven or Broken:</b>	Truck beds <input type="checkbox"/>		
	Rail car floors <input type="checkbox"/>		
	Walking surfaces <input type="checkbox"/>		

### 3. Slips/Falls and Loss of Balance Hazard Assessment

	Check (✓) if Condition is Present	Process Currently Implemented to Prevent and/or Control Condition	Notes Regarding Recommended Changes
	Platforms <input type="checkbox"/>		
	Stairways <input type="checkbox"/>		
	Scaffolds <input type="checkbox"/>		
	Outdoor yards <input type="checkbox"/>		
	Any other working surfaces <input type="checkbox"/>		

#### Part E. Special Considerations

	Check (✓) if Condition is Present	Description of Slips/Falls and Loss of Balance Controls in Place	Notes Regarding Recommended Changes
<b>Unique Considerations</b>	Areas Used by Individuals with Physical Disabilities <input type="checkbox"/>		
	Areas Used by Elderly Individuals or Children <input type="checkbox"/>		
	Traffic (Motor Vehicles) Areas <input type="checkbox"/>		
	Areas Used by Visitors <input type="checkbox"/>		

### 3. Slips/Falls and Loss of Balance Hazard Assessment

	Check (√) if Condition is Present	Description of Slips/Falls and Loss of Balance Controls in Place	Notes Regarding Recommended Changes
	Construction Areas <input type="checkbox"/>		
	Heavy Machinery Areas <input type="checkbox"/>		

#### Part F. Working at Heights

Conditions	Check (√) if condition exists	Description of Controls 'at the source'	Description of Controls 'along the pathway'	Description of Controls 'at the worker'	Check if Additional Controls Recommended
<b>Work at Heights with:</b>	Portable ladders <input type="checkbox"/>				<input type="checkbox"/>
	Fixed ladders <input type="checkbox"/>				<input type="checkbox"/>
	Elevated Platforms <input type="checkbox"/>				<input type="checkbox"/>
	Scaffolds <input type="checkbox"/>				<input type="checkbox"/>
	Aerial Lift Vehicles <input type="checkbox"/>				<input type="checkbox"/>
	Scissor Lift <input type="checkbox"/>				<input type="checkbox"/>
	Personal Man Lift <input type="checkbox"/>				<input type="checkbox"/>

### 3. Slips/Falls and Loss of Balance Hazard Assessment

Conditions	Check (✓) if condition exists		Description of Controls 'at the source'	Description of Controls 'along the pathway'	Description of Controls 'at the worker'	Check if Additional Controls Recommended
	Lift Truck (with use of an approved lifting platform)	<input type="checkbox"/>				<input type="checkbox"/>
	Catwalks	<input type="checkbox"/>				<input type="checkbox"/>
	Other elevating devices	<input type="checkbox"/>				<input type="checkbox"/>

Comments Regarding Controls Pertaining to Working at Heights:

## 4. Sample Slips/Falls and Loss of Balance (from heights) Standard Operating Procedure (SOP)

Tasks/Process: <b>SLIPS/FALLS AND LOSS OF BALANCE FROM HEIGHTS</b>	Department:
Prepared/Revised By:	Approved:
Supersedes:	Date Issued:

### Purpose

The purpose of this standard operating procedure is to provide a protocol for the development of procedures and practices that will minimize the risk of persons being injured or harmed by falling from heights. It is also intended that this procedure will assist the firm in ensuring compliance with the Occupational Health and Safety Act and the Regulation for Industrial Establishments (R.R.O. 851).

### Scope

The application of this procedure is intended to cover:

- ▶ fall arrest/travel restraint systems;
- ▶ scaffolds;
- ▶ ladders;
- ▶ mobile access platforms; and
- ▶ access/egress on machinery.

This procedure is applicable to all employees and contractors associated with the firm.

### Responsibilities

**Senior Management** is responsible for:

- ▶ ensuring that work sites undergo (as needed) a Slips/Falls Hazard Assessment to identify where the potential for slips/falls from heights exist;
- ▶ establishing a team of qualified persons to determine the best means of controlling exposures to slips/falls from heights as per the specific situation;
- ▶ developing procedures/practices for those activities and equipment identified for use in controlling the potential exposure;

The team should consist of a minimum of the:

- ▶ maintenance manager,
- ▶ department supervisor; and
- ▶ worker.



#### 4. Sample Slips/Falls and Loss of Balance (from heights) Standard Operating Procedure

---

- ▶ ensuring that all the procedures and practices for slips/falls prevention and protection is communicated to supervisors and workers;
- ▶ maintaining all records associated with this SOP; and
- ▶ annual review of this SOP.

If a health and safety coordinator or resource is on-site, certain employer responsibilities may be delegated as appropriate.

Note – a health and safety coordinator with fall protection responsibilities must have the knowledge in maintaining a fall protection program including:

- ▶ selection of equipment
- ▶ inspecting equipment
- ▶ procedure writing
- ▶ emergency rescue procedures
- ▶ training employees

The **supervisor** is responsible for:

- ▶ knowledge of the Occupational Health and Safety Act as well as any applicable regulations;
- ▶ participating in any slips/falls team (associated with the supervisor's department) that is:
  - developing procedures and practices intended to prevent and protect workers from slips/falls;
- ▶ ensuring that the procedures and practices developed are adhered to by all workers within his or her department;
- ▶ ensuring that all workers involved in the procedures and practices are adequately trained; and
- ▶ responding immediately to all concerns of:
  - identified substandard conditions;
  - hazards;
  - defects; or
  - non-compliance of the procedures and practices for slips/falls prevention and protection.

#### 4. Sample Slips/Falls and Loss of Balance (from heights) Standard Operating Procedure

---

**Workers** at risk of being injured or harmed by falling from heights are responsible for:

- ▶ participating in any slips/falls team that is developing practices and procedures for slips/falls prevention and protection;
- ▶ inspecting all pieces of relevant equipment – as required by the practices and procedures for slips/falls prevention and protection; and
- ▶ recording the findings of all equipment inspections.

**ALL workers** are responsible for:

- ▶ abiding by all procedures and practices for slips/falls prevention and protection;
- ▶ immediately reporting to the supervisor any identified:
  - identified substandard conditions;
  - hazards;
  - defects; or
  - non-compliance of the procedures and practices for slips/falls prevention and protection.

The **Slips/Falls Hazard Assessment Team (or JHSC)** is responsible for:

- ▶ reviewing the accident and inspection reports to identify slips/fall occurrences and locations;
- ▶ reviewing the SOP and recommending areas of improvement for Slips/Falls Hazard prevention.

### Procedure

Priority will be given to eliminating the need to ‘work at heights’. Elimination can be accomplished by ‘engineering out’ the need to do the ‘work at height’s (e.g., remove the need to work at heights through operation and workspace design). Alternatively, elimination can be accomplished by hiring external contractors to complete the work who are qualified, competent and knowledgeable.

‘Working from heights’ tasks that cannot be ‘engineered out’ will be controlled by installing or using:

- ▶ permanent walkways with guardrails;
- ▶ mobile access platforms/scaffolds;
- ▶ ladders/step ladders; and/or
- ▶ fall arrest systems/fall restraint system.

It should be recognized that controls such as permanent walkways with guardrails are a better form of control than simply using a ladder, and/or a fall arrest system. When ‘working from heights’ tasks cannot be ‘engineered out’, first consideration should be given to such superior controls.

Controlling the hazard may involve the use of more than one means of control. In general, the greater the risk the greater number of controls should be in place.

Once the control methods have been determined, pertaining to each method, the slips/falls team (or JHSC) must research and review relevant:

- ▶ guidelines;
- ▶ standards;
- ▶ regulations; and
- ▶ best practices.



(Refer to the General Best Practices section and guidelines for more information relevant to best practices.)

Based upon the results of their research, the team shall create step-by-step procedures. The procedures developed will explicitly address the needs of the work at hand. The procedures will be incorporated into the health and safety program manual for future reference.

### **Training**

The health and safety coordinator will ensure that all procedures and practices for slips/falls prevention and protection be communicated to supervisors and workers.

The department supervisor will ensure that all workers affected by procedures and practices for slips/falls prevention and protection have been trained in the following:

- ▶ the slips/falls protection procedures/practices;
- ▶ the use, inspection, maintenance, storage and handling of all related equipment;
- ▶ the hazards associated with working at heights;
- ▶ rescue and emergency procedures; and
- ▶ any other relevant training.

Training will include both theory and practice. Training participants must demonstrate “hands-on” competency in all training components and equipment prior to using procedures and practices for slips/falls prevention and protection on the job.

### **Control Monitoring**

An inventory of the hazard controls for slips/falls prevention that are supposed to be in place will be drawn up. A program will be developed to monitor how controls are working in practice. The Joint Health and Safety Committee (JHSC) will be issued a copy of the monitoring results.

## 5. Sample Slips/Falls and Loss of Balance (same elevation) Standard Operating Procedure (SOP)

Tasks/Process: <b>SLIPS/FALLS AND LOSS OF BALANCE (same elevation)</b>	Department:
Prepared/revised by:	Approved:
Supersedes:	Date Issued:

### Purpose

The purpose of this standard operating procedure is to provide a protocol for the development of procedures and practices that will minimize the risk of persons being injured or harmed during work through exposure to slipping, falling or loss of balance hazards. This procedure will assist the firm meet compliance with Occupational Health and Safety Act and the Regulation for Industrial Establishments (R.R.O. 851).

### Scope

This procedure will apply to same elevation working surfaces with exposure to slips, falls and/or loss of balance hazards.

### Responsibilities

The **health and safety coordinator** is responsible for:

- ▶ ensuring that work sites undergo (as needed) a Slips/Falls Hazard Assessment to identify where the potential for slips/falls and loss of balance hazards exist;
- ▶ establishing a team of qualified persons to determine the best means of controlling exposures to slips/falls from the same elevation as per the specific situation;
- ▶ developing procedures/practices for those activities and equipment identified for use in controlling identified slips/falls and loss of balance hazards;
- ▶ ensuring that all the procedures and practices for slips/falls prevention and protection is communicated to supervisors and workers; and
- ▶ maintaining all records associated with this SOP.

The team should consist of a minimum of the:

- ▶ maintenance manager,
- ▶ department supervisor; and
- ▶ worker.

Note – a health and safety coordinator with fall protection responsibilities must have the knowledge in maintaining a fall protection program including:

- ▶ selection of equipment
- ▶ inspecting equipment
- ▶ procedure writing
- ▶ emergency rescue procedures
- ▶ training employees

The **supervisor**:

- ▶ participating in any slips/falls team (associated with the supervisor's department) that is:
  - developing procedures and practices intended to prevent and protect workers from slips/falls;
- ▶ ensuring that the procedures and practices developed are adhered to by all workers within his or her department;
- ▶ ensuring that all workers involved in the procedures and practices are adequately trained; and
- ▶ responding immediately to all concerns of:
  - identified substandard conditions;
  - hazards;
  - defects; or
  - non-compliance of the procedures and practices for slips/falls prevention and protection.

**Workers** that are at risk of being injured or harmed during work through exposure to slipping, falling or loss of balance hazards are responsible for:

- ▶ participating in any slips/falls team that is developing practices and procedures for slips/falls prevention and protection;
- ▶ abiding by all procedures and practices for slips/falls prevention and protection;
- ▶ inspecting all pieces of relevant equipment - as required by the practices and procedures for slips/falls prevention and protection; and
- ▶ recording the findings of all equipment inspections.

**ALL workers** are responsible for:

- ▶ abiding by all procedures and practices for slips/falls prevention and protection;
- ▶ immediately reporting to the supervisor any identified:
  - identified substandard conditions;
  - hazards;
  - defects; or
  - non-compliance of the procedures and practices for slips/falls prevention and protection.

The **maintenance manager** is responsible for:

- ▶ actively participating in any team identified to develop procedures/practices for slips/falls protection.

### Procedure

Controlling a hazard means eliminating the hazard or reducing it to a level that protects workers from its adverse effects. The priority for controlling hazards will start with controls at the **source**. Examples of effective controls at the source include:

- ▶ substitution of a non-hazardous surface (control for slip hazards);
- ▶ workstation and workplace redesign to provide for surfaces with a uniform coefficient of friction (coefficient of friction for surfaces should be tested to ensure they are above .5);
- ▶ safe work design and good housekeeping;
- ▶ safe design of stairs, ramps, scaffolds and ladders; and
- ▶ quality preventive maintenance program for stairs, ramps, scaffolds, ladders and other surfaces.

If unable to eliminate or put controls in at the source, controls along the path from the source to the worker will be implemented. Examples of controls along the path to the worker include:

- ▶ highlighting;
- ▶ posting; and
- ▶ guarding.

At the level of ‘the worker’ hazards can be further reduced by such practices as:

- ▶ good education and training programs; and
- ▶ use of boots with slip-resistant soles suited to the surface the worker is on.

Once the control methods have been determined, pertaining to each method, the slips/falls team must research and review relevant:

- ▶ guidelines;
- ▶ standards;
- ▶ regulations; and
- ▶ best practices.



(Refer to the General Best Practices section and guidelines for more information relevant to best practices.)

Based upon the results of their research, the team shall create step-by-step procedures. The procedures developed will explicitly address the needs of the work at hand. The procedures will be incorporated into the health and safety manual for future reference.

### **Training**

All workers in the workplace should be given some training about all the walking and working surfaces in the workplace. In this way they will be able to recognize the hazards associated with those surfaces and understand how they can be controlled.

For workers exposed to slips/falls and loss of balance hazards a quality training plan will be implemented that covers:

- ▶ safe movement on surfaces;
- ▶ principles of safe design;
- ▶ legislated requirements;
- ▶ inspection and preventive maintenance;
- ▶ selection, fitting, use and care of relevant personal protective equipment;
- ▶ good housekeeping;
- ▶ safe work procedures;
- ▶ recognition of musculoskeletal injuries and symptoms associated with slips, trips, falls and loss of balance; and
- ▶ all procedures and practices developed to prevent and protect workers from slips/falls and loss of balance.

Training participants must demonstrate “hands-on” competency in all training components including:

- ▶ identification and assessment of slips, fall and loss of balance hazards;
- ▶ selection, fitting, use and care of relevant personal protective equipment; and
- ▶ application of all procedures and practices developed to prevent and protect workers from slips/falls and loss of balance.

### **Control Monitoring**

An inventory of the hazard controls for slips/falls and loss of balance prevention that are supposed to be in place will be drawn up. A program will be developed to monitor how controls are working in practice. The Joint Health and Safety Committee (JHSC) will be issued a copy of the monitoring results.



## **6. Hazard Control Information – Slips/Falls and Loss of Balance (from same elevation and heights)**

### **6a. General Best Practices**

Companies that effectively minimize the risk of slips/falls and loss of balance implement practices such as:

1. Keeping pedestrian routes and circulation areas separate from work areas.
2. Having policies and processes to ensure that an investigation is made into all fall related incidents regardless of whether or not an injury has occurred. (Investigations review the adequacy of the fall protection system and produce recommendations for improvement to prevent potential recurrence.)
3. Having a policy that sets out accountabilities and responsibilities for good housekeeping practices including:
  - routine sweeping or vacuuming of walking surfaces;
  - routine sweeping of outdoor pedestrian routes;
  - regularly removing snow and using salt and/or sand as appropriate on outdoor pedestrian routes during snowy and icy conditions;
  - using polishes and sealers on the floor that do not reduce slip resistance;
  - using barriers, signs and/or notices to keep people away from areas being cleaned or polished; and
  - having procedures that ensure liquid contamination on the floor is dealt with immediately.
4. Ensuring adequate lighting is provided in all areas (elevated spaces in particular are well illuminated).
5. Installing handrails on stairs, ramps and other locations with increased risk of loss of balance, and where appropriate anti-slip tread is installed.
6. Using signs, barriers, lighting, etc. to clearly identify changes in floor level.
7. Educating employees and requiring that they keep filing cabinets and drawers closed when not in use.

## **6. Hazard Control Information – Slips/Falls and Loss of Balance (from same elevation and heights)**

8. Tying down cords from phones, typewriters, lights, computers, etc.
9. Responding immediately (as per company policies and procedures) to:
  - loose or damaged floor coverings; and
  - identified slip, trip and fall hazards.
10. Regularly assessing floors for slip resistance and responding to improve slip resistance as warranted; for example by:
  - installing adequate and secure doormats or abrasion strips to prevent slipping; and
  - ensuring appropriate footwear is worn for the type of work process (e.g., material and tread design).

<b>6b. Fall Protection Systems</b>				
	<b>Training</b>	<b>Use</b>	<b>Maintenance and Inspection</b>	<b>Discarding Product</b>
<p><b>General Information regarding:</b></p> <p><b>Fall Arrest Systems</b></p> <p><b>and</b></p> <p><b>Travel Restraint Systems</b></p>	<p>Proper training for workers is essential for either system.</p> <p>The training program must include:</p> <ul style="list-style-type: none"> <li>▶ individual-fit testing of equipment; and</li> <li>▶ demonstration of competency in performing a pre-inspection of the system (competency must be demonstrated before use)</li> </ul>	<p>Companies must distinguish which system is needed for their application.</p> <p>A fall arrest system always requires:</p> <ul style="list-style-type: none"> <li>▶ use of a full body harness;</li> <li>▶ that workers never work alone; and</li> <li>▶ free-fall distance be kept to a minimum.</li> </ul> <p>Rescue plans need to be in place in case of a fall situation or other emergency.</p>	<p>Store all equipment in a clean, dry place away from direct sunlight.</p> <p><u>Worker</u>: conduct daily pre-inspections.</p> <p><u>Competent Person</u>: conduct semi-annual inspections</p> <p>Record inspections. Information on <b>every</b> piece of equipment (no matter how small) in a fall protection program should be documented including:</p> <ul style="list-style-type: none"> <li>▶ type of use;</li> <li>▶ nature of environment; etc.</li> </ul> <p>Re-evaluate fall protection program on an ongoing basis.</p>	<p>If a fall arrest or travel restraint system fails the formal inspection process it must be <b>marked UNUSABLE</b> and discarded.</p>
<p><b>Full-Body Harness</b></p>	<p>Companies should distinguish what type of full-body harness is to be used in their fall prevention program and train workers to:</p> <ul style="list-style-type: none"> <li>▶ know the difference between the different harnesses;</li> <li>▶ know all of the components of a full body harness;</li> <li>▶ know when and how to apply it to each type of system used</li> </ul>	<p>Companies must state the workplace-specific circumstances and areas where a full-body harness is to be used.</p> <p>(e.g. Locations over 3 m in height from the Industrial Establishments Regulations).</p>	<p>Follow manufacturer’s instructions regarding the service life of belts and harnesses.</p> <p>Clean the harness with a mild detergent (not a harsh cleaner or solvent) when the task is completed.</p> <p>Check:</p> <ul style="list-style-type: none"> <li>▶ for cuts, abrasions or open stitching;</li> <li>▶ for chemical or heat damage;</li> <li>▶ the adjustment plate holding the D-ring <b>and</b> the D-ring for distortion, cracks, or other damage; and</li> <li>▶ for kinks and twists (once the harness has been put on).</li> </ul>	<p>If a harness fails the formal inspection process it must be <b>marked UNUSABLE</b> and discarded</p>
<p><b>Shock Absorbing Lanyards</b></p>	<p>Companies should determine what type of shock absorbing lanyard (e.g. material, length) should be used in their fall prevention program and train workers on their use.</p>	<p>Companies must state the workplace-specific circumstances and areas where a shock-absorbing lanyard is to be used.</p>	<p>Check:</p> <ul style="list-style-type: none"> <li>▶ to see if the warning tag has come out;</li> <li>▶ the outer jacket for signs of damage; and</li> <li>▶ the end loops for damage, cracks, etc.</li> </ul>	<p>Remove and replace the damaged shock absorbing lanyard if it is damaged.</p>

<b>6b. Fall Protection Systems</b>				
	<b>Training</b>	<b>Use</b>	<b>Maintenance and Inspection</b>	<b>Discarding Product</b>
<b>Lanyards</b>	Companies should determine what type of other lanyards (e.g. material, length) should be used in their fall prevention program and train workers on their use.	<p>The lanyard used must be appropriate for the type of system (different lanyards are used for fall arrest versus travel restraint systems).</p> <p>Never tie knots in lanyards.</p> <p>Never use lanyards that are not approved by the manufacturer for fall prevention use.</p>	<p>Check:</p> <ul style="list-style-type: none"> <li>▶ the service life with the manufacturer (typically service life is five years); and</li> <li>▶ for cracks, distortion and damage.</li> </ul>	<p>Lanyards must be <b>retired immediately</b> under the following conditions:</p> <ul style="list-style-type: none"> <li>▶ after a fall;</li> <li>▶ when an integral shock absorber has been totally or even partially deployed;</li> <li>▶ the lanyard has been used for any purpose other than fall protection; and</li> <li>▶ when an inspection reveals the integrity of the lanyard is compromised.</li> </ul> <p>A retired lanyard should be <b>cut in two</b> to ensure it is never used again.</p>
<b>Snap Hooks/ Connecting Hardware</b>	Companies should determine what type of other connecting hardware/snap hooks (e.g., carabiners, double locking only, size) should be used in their fall prevention program and train workers on their use.	Snap hooks must be connected to compatible hardware and must never be attached to another snap hook.	<p>Check:</p> <ul style="list-style-type: none"> <li>▶ the snap hook for damage, pitting, and distortion;</li> <li>▶ that the spring has enough tension to close the keeper; and</li> <li>▶ that the keeper and double locking mechanism work properly without binding or excessive lateral play.</li> </ul>	<p>Snap Hooks/ Connecting hardware should be retired immediately under the following conditions:</p> <ul style="list-style-type: none"> <li>▶ after a fall;</li> <li>▶ when an inspection reveals the integrity of the hooks/ hardware is compromised</li> </ul>

<b>6b. Fall Protection Systems</b>				
	<b>Training</b>	<b>Use</b>	<b>Maintenance and Inspection</b>	<b>Discarding Product</b>
<b>Ropes/ Lifelines</b>	Safe use of ropes requires skill, training and practice. Ensure that the user is qualified to use the type of rope being used and is aware of the rope's limitations.	<p>Many different types of ropes exist (e.g., kernmantle, braided, twisted, manila, hemp, jute, nylon, polyester, polypropylene, polysteel, kevlar, spectra, etc.). The right type must be used based on the application.</p> <p>Ropes of natural fibres must never be used for vertical lifelines.</p> <p>Vertical lifelines should be at least 16mm diameter polypropylene or other material of equal strength.</p> <p>Ropes must be protected over sharp edges</p> <p>Do not allow rope to come into contact with acids, oils, or other chemicals.</p> <p>Do not use knots in ropes (this reduces their strength by up to 50%).</p>	<p>Keep ropes clean.</p> <p>Check:</p> <ul style="list-style-type: none"> <li>▶ for areas where the rope material is separating and out of shape;</li> <li>▶ for broken fibres and severely worn areas of the protective sheath; and</li> <li>▶ the eyes of the rope for deformities or cracks.</li> </ul>	<p>If any part of the rope is damaged in any way, it is to be immediately discarded.</p> <p>Place a tag or other mode of notification identifying the rope as damaged and indicating that it is to be discarded.</p>
<b>Retractable Lifelines</b>	Safe use of retractable lifelines requires skill, training and practice. Ensure that the user is qualified for the type of retractable lifeline being used and is aware of the lifeline's limitations.	<p>Prior to use, confirm that the system is certified. Retractable lifelines usually need to be certified on a yearly basis (or sooner based on the working environment).</p> <p>Certification is achieved through the manufacturer or an approved agent.</p>	<p>Prior to each use, and in accordance with manufacturer's recommended frequency, inspect the:</p> <ul style="list-style-type: none"> <li>▶ self-retracting lifeline;</li> <li>▶ locking mechanism; and</li> <li>▶ braking mechanism.</li> </ul> <p>Due to the nature and complexity of the retracting mechanism, overhaul, inspection and maintenance should be left to a competent and knowledgeable person.</p>	Check manufacturer standards/ suggestions for when to discard.
<b>Rope Grab</b>	Safe use of rope grabs requires skill, training and practice. Ensure that the user is aware of the type of rope grab being used, qualified to use it and is aware of its limitations.	Ensure the rope grab is mounted right side up (look for the directional arrow).	Check for corrosion, distortion, and secure mounting.	Check manufacturer standards/ suggestions for when to discard.

<b>6b. Fall Protection Systems</b>				
	<b>Training</b>	<b>Use</b>	<b>Maintenance and Inspection</b>	<b>Discarding Product</b>
<b>Anchor Points</b>	<p><b>Note – See:</b></p> <ul style="list-style-type: none"> <li>▶ Anchorage Planning: The Key to Fall Protection, Safety and Health, September 1991</li> </ul>	<p>The fall arrest anchor point used must be able to absorb twice the energy and twice the load that may be transmitted to it.</p> <p>Do not use one anchor for multiple lifelines.</p> <p>Do not confuse fall arrest anchor points with travel restraint anchor points. Clearly mark a distinction between the two if both are used.</p>	<p>Consult the manufacturer’s recommendations for use, inspection, care and maintenance. (All components of an anchor system must be inspected.)</p>	N/A
<b>Webbing</b>	<p>Companies should determine what type of webbing (nylon, polyester, kevlar) is appropriate for the work environment and train workers on proper maintenance and storage.</p>	<p>Webbing that is part of the full body harness or other fall protection equipment, such as a sling, should be selected and rated for the task/ work environment where it is used.</p>	<p>Check:</p> <ul style="list-style-type: none"> <li>▶ all webbing for tears, fraying, pulled stitches, cuts, burns or other damage;</li> <li>▶ that grommets are not loose or broken; and</li> <li>▶ the tongue area of belt or harness for normal wear</li> </ul>	<p>Webbing that is incorporated into a full body harness or other fall protection equipment should be discarded immediately after a fall or when an inspection reveals the integrity of the webbing is compromised.</p> <p>Check manufacturer standards/ suggestions for additional information on when to discard.</p>

Note – For additional information on fall protection refer to the Construction Projects Regulations.

**6. Hazard Control Information – Slips/Falls and Loss of Balance (from same elevation and heights)**

<b>6c. Equipment – Working from Heights</b>			
	<b>Installation/Setup</b>	<b>Use</b>	<b>Maintenance/ Inspection</b>
<b>Scaffolds</b>	<p>Erection of a scaffold should be done by a competent person knowledgeable in scaffold erection.</p> <p>Install only on flat, hard ground or flooring.</p> <p>Ensure handrails are in place.</p> <p>Never exceed the base to height ratio as recommended by the manufacturer.</p>	<ol style="list-style-type: none"> <li>1. Place barriers and warning signs in the vicinity of the work being performed.</li> <li>2. Lock castor wheels when the scaffold is in use (wheels <u>must</u> have locks).</li> <li>3. Never exceed the specified working load.</li> <li>4. Use toeboards to prevent items from falling off.</li> </ol>	<p>Routinely inspect scaffolds (or as specified by the manufacturer).</p> <p>Inspections of scaffolds should be done by a competent person. Inspections should be conducted prior to use.</p> <p>Document inspections (required).</p>
<b>Guardrails</b>	<p>Install Guardrails at the edges of floor openings, stairways, landings, platforms, rooftops, scaffolds, shafts, etc. where there is a potential fall hazard.</p> <p>Refer to Section 13 of the Regulations for Industrial Establishments.</p> <p>Ensure guardrails are constructed of material adequate to support the load that will potentially be applied to it.</p> <p>Secure rails and toeboards to the inside of posts or jacks.</p>	<p>See Ministry of Labour data sheet on Guardrails, data sheet 2-05</p>	<p>Refer to Section 14 of the Industrial Establishment Regulations for construction of a guardrail.</p> <p>If construction project is happening in an Industrial Establishment, guardrail systems must also meet the requirements of the Construction Projects Regulation, s.26.3 (7).</p>
<b>Mobile Access Platforms</b> (e.g., elevating work platforms, aerial lifts, scissor lifts, and manlift cages)	<p>Always review manufacturers' instructions prior to using the platform for the first time.</p> <p>The platform should have clearly and visibly marked on it the safe working load.</p> <p>Ensure that the area overhead is clear of overhead structures or services (e.g., wires, piping, lighting etc.).</p> <p>The surface under the platform should be flat and without gradient.</p>	<p>Note – users of mobile access platforms <b>must</b> be trained in their use and records of training kept.</p> <ol style="list-style-type: none"> <li>1. Do not drive or move the platform when in the raised position.</li> <li>2. Place barriers and warning signs around the work vicinity.</li> <li>3. Ensure no one is in the way when lowering the platform (e.g., no one can get caught under or in the lowering mechanism).</li> <li>4. Wear a full-body harness attached to a fall protection system while in the basket or on the platform. Refer to the manufacturer's specifications to determine the best anchor point.</li> </ol>	

## 6c. Equipment – Working from Heights Continued

### Ladders

For any organization using ladders, ladder policies and a ladder safety/awareness program is important. A policy on ladders should cover:

- ▶ Use;
- ▶ Inspection;
- ▶ Storage; and
- ▶ Disposal.

A ladder safety/awareness program should, at a minimum, address the following **Elements**:

- ▶ Application;
- ▶ Selection;
- ▶ Training;
- ▶ and Procedures.

The sections below and on the following pages outline key considerations for each element. It is important to note that these are only some elements of a ladder safety program, and only some considerations. To provide for the safe use of ladders it is important that you develop, maintain and update a program specific to the needs of your workplace.

### Application

The first step is to determine how a ladder will be applied by analyzing the situation. The results of your analysis will help you with the second step-selection.

Consider the job for which you will be using a ladder and ask yourself questions such as those outlined below

#### **Task:**

- ▶ What is the type of work you will be doing?
- ▶ What will be the potential uses of the ladder?
- ▶ Will the ladder be used for tasks other than those for which you purchased the ladder?

#### **Location:**

- ▶ Where will you be using the ladder?
- ▶ Will you be working near live electricity, above ground or underground, in high or low traffic areas?



**Time:**

- ▶ What will be the frequency of use?
- ▶ How long will you be using the ladder?

**Necessity:**

- ▶ Is a ladder required for the job?
- ▶ Are there alternative means of elevation, e.g., a scaffold?

**Selection**

If you have determined a ladder is necessary and you know the details of how it will be applied, your second step is to select the type and class of ladder required.

When making your selection consider:

- ▶ Manufacturer recommendations (it is important to use ladders only as recommended):
  - if in doubt, always use a Grade One Heavy Duty Industrial ladder with a load rating of 250 lbs.
- ▶ Ladder configuration:
  - do you require a fixed ladder, an extension ladder, a step ladder, or another access fixture such as a portable staircase?
- ▶ The possibility of electrical contact:
  - if electrical contact is a possibility, select a wooden (without wire reinforcement) or fibre glass ladder (see section 43 of the Industrial Establishment Regulation).
- ▶ Your needs regarding ladder size and material:
  - select a ladder to suit the job; one size and material does not fit all jobs.
- ▶ The accessories or additions that may be required.

Contact ladder manufacturers to determine what is available to suit your needs. In all cases, make sure you do not tamper with the structure of the ladder.

**Training**

Prior to using ladders, training should be provided that:

- ▶ includes use of ladders from a “hands-on” format;
- ▶ is specific to the equipment to be used and work to be done;
- ▶ addresses proper climbing techniques (emphasizing the requirement for maintaining three point contact when climbing up or down); and
- ▶ compares best practices to unsafe practices.

For all training elements it is important to have established standards. It is also essential that proper training be provided to those who will be inspecting the ladders on what to look for/how to inspect ladders. (Note, most ladder manufacturers have inspection checklists that can be downloaded from their website.)

## 6. Hazard Control Information – Slips/Falls and Loss of Balance (from same elevation and heights)

### Procedures

It is essential that organizations develop procedures regarding ladders. Outlined below are various points for consideration when developing procedures pertaining to ladders.

Provision of Information	Ladder Installation/ Setup	Ladder Implementation	Ladder Maintenance/ Inspection
<p>Appropriate instruction regarding any workplace related safety hazards must be provided to workers as required by clauses 25(2)(a) and 25(2)(d) of the <i>Occupational Health and Safety Act</i>:</p> <p>▶ All employers "shall provide information, instruction and supervision to a worker to protect the health and safety of the worker" and "shall acquaint a worker or a person in authority over a worker with any hazard in the work and in the handling, storage, use, disposal and transport of any article, device, equipment or a biological, chemical or physical agent."</p> <p>Workers must (also) be informed of procedures required under appropriate regulations; refer to:</p> <p>▶ the Regulations for Industrial Establishments Reg. 851/90), sections 18, 19, 45, 46, 73, 74 and 85.</p> <p>▶ the Regulations for Construction Projects (0. Reg. 213/91), sections 78 to 84.</p> <p>Read and follow instructions on manufacturer's labels affixed to the ladder.</p>	<p>Fit all ladders and stepladders with appropriate non-slip feet.</p> <p>Ensure portable ladders are CSA certified for their type of use in the workplace.</p> <p>Do not stand ladder on snow, ice or other slippery contaminants.</p> <p>Make sure the ground or floor has level, solid flooring.</p> <p>Place ladder at a tilt of 70-75 degrees (gradient of 1:4). (One foot back for each four feet up.) (Industrial Establishment Regulation s.73)</p> <p>Always ensure that ladders are properly secured, providing for proper footing, stability, tie offs, etc.:</p> <p>▶ Secure the ladder; if not practical, then a second person must foot the base at all times.</p> <p>▶ Secure the top and bottom of the ladder if using it to access a platform or scaffold.</p> <p>Always ensure the ladder is properly set up for the position of the work you will be doing.</p> <p>Get help when moving heavy or long ladders.</p> <p>Where there is the danger of traffic, have someone hold the ladder. Post a warning sign, if necessary.</p>	<ol style="list-style-type: none"> <li>1. Consider an elevated work platform instead of a ladder for work at elevation indoors.</li> <li>2. For fixed ladders, use a vertical lifeline that runs the entire length of the ladder.</li> <li>3. Use fall protection controls when performing work on a ladder that has a fall distance of three metres or more.</li> <li>4. Use fibreglass ladders for work near electrical installations. (Do not use metal or wood ladders, or stepladders.) (Industrial Establishments Regulation s.85)</li> <li>5. Lock doors or fully open doors in the vicinity of a ladder in use.</li> <li>6. Open ladder fully.</li> <li>7. Never use the top two rungs of a ladder as a step. (For stepladders, never stand on the top or pail shelf.)</li> <li>8. Maintain three-point contact and always face the ladder when climbing or descending a ladder.</li> <li>9. Never use a painted wooden ladder.</li> <li>10. Use ladders that are the correct height (to avoid reaching or stretching).</li> <li>11. Wear shoes that are clean and have a well defined heel.</li> <li>12. Place warning signs in vicinity of the area where work is being performed.</li> <li>13. Where practical, ensure that two workers are present when a ladder is being secured or released.</li> </ol>	<p>Establish safe use, storage and maintenance practices for ladders.</p> <p>Ensure you have a hazard reporting procedure.</p> <p>Prior to each use inspect the profile and condition of the:</p> <ul style="list-style-type: none"> <li>▶ safety feet/ladder footing;</li> <li>▶ side rails; and</li> <li>▶ rungs (remember to check for oil or grease which can make climbing surfaces slippery).</li> </ul> <p>Complete periodic inspections of ladders and stepladders. Inspections should be documented and signed-off.</p> <p>Always ensure that inspections and repairs are conducted by qualified workers.</p> <p>Unsafe ladders and stepladders must be tagged and taken out of service until repaired</p> <p>Do not make temporary or makeshift repairs (e.g., no tying or binding with wire).</p> <p>Destroy any ladder that cannot be properly repaired.</p> <p>Do not try to straighten or attempt to use bent or bowed ladders.</p> <p>Do not paint a ladder (paint can hide cracks and weak points).</p> <p>Inspection Checklist for ladders:</p> <ul style="list-style-type: none"> <li><input type="checkbox"/> Rungs (tight, not movable by hand)</li> <li><input type="checkbox"/> Nails, screws, bolts or other metal parts tight</li> <li><input type="checkbox"/> Uprights, braces and rungs in good condition</li> </ul>

**6. Hazard Control Information – Slips/Falls and Loss of Balance (from same elevation and heights)**

Provision of Information	Ladder Installation/ Setup	Ladder Implementation	Ladder Maintenance/ Inspection
		<p>14. Keep areas at the base and the top of the ladder free from obstructions.</p> <p>15. Always ensure that rescue procedures are in place in the event of an emergency.</p> <p>16. Hoist materials or attach tools to a belt (do not carry objects in your hands when ascending or descending a ladder).</p> <p>17. Do not use makeshift items such as a chair, barrel or box as a substitute for a ladder.</p> <p>18. Do not lean beyond the side rails.</p> <p>19. Make sure that only one person at a time is on the ladder.</p> <p>20. Never use a stepladder as a straight ladder.</p> <p>21. Lock stepladders; spread the legs to their limit and ensure the braces are locked.</p> <p>22. Ensure that ladders are placed 1m above the landing platform. Use a different sized ladder if the current ladder can not achieve this.</p>	<p><input type="checkbox"/> Wooden parts (smooth, no splinters or cracks)</p> <p><input type="checkbox"/> Non-slip safety feet (in proper condition)</p> <p><input type="checkbox"/> Ladder stable</p> <p><input type="checkbox"/> Hinge spreaders (tight, straight)</p> <p><input type="checkbox"/> Hinges (tight)</p> <p><input type="checkbox"/> Extension locks (in place, in good condition)</p> <p><input type="checkbox"/> Rope (undamaged)</p> <p><input type="checkbox"/> Identification marks (legible)</p> <p><input type="checkbox"/> Ladder stored properly when not in use</p>

This material was contributed to by representatives of the Ontario Safe Workplace Associations and representatives of Ontario ladder manufacturers. For more information, contact your Safe Workplace Association, your Industry Association, or a ladder manufacturer.

### 6d. Slippery Surface – Controlling Hazards at the Source

Slippery surface hazards can be controlled at the source by setting a slip-resistant surface over a slippery surface. This can be done by four means: matting, self-adhesive flooring, wall-to-wall flooring and coatings.

Surface Type	Description	Construction and Installation	Typical Use
<p><b>Matting</b></p> <p>(Matting is the most widely used anti-slip surface.)</p>	<p>Anti-slip surface usually not fixed in place.</p> <p>Consists of vinyl or moulded rubber that provides drainage for moisture and spills.</p>	<p>Matting usually has an open grid construction or is perforated to achieve drainage. The surface is typically serrated to provide additional slip resistance. The serration also serves to scrape slippery substances from the soles of workers' boots.</p> <p>Alternatively, matting can have a coating of mineral particles or have particles incorporated in it that produce similar effects.</p> <p>Matting:</p> <ul style="list-style-type: none"> <li>▶ is relatively easy to install;</li> <li>▶ can be cut to size and laid where it is needed; and</li> <li>▶ can be easily removed for cleaning.</li> </ul>	<p>Suited to workplaces where floors tend to be wet or greasy.</p> <p>Commonly used:</p> <ul style="list-style-type: none"> <li>▶ along assembly lines;</li> <li>▶ in commercial kitchens; and</li> <li>▶ along aisles in warehouses where there are slip hazards.</li> </ul>
<p><b>Self-adhesive Flooring</b></p>	<p>Anti-slip surface that is fixed permanently to the floor.</p> <p>Consists of a textured sometimes abrasive surface backed with a strong adhesive.</p>	<p>Abrasive surfaces are achieved by a coating of silicon carbide or aluminum oxide. (Aluminum oxide has the advantage that the particles are more durable and so keep their abrasive edges longer.)</p> <p>Self-adhesive flooring:</p> <ul style="list-style-type: none"> <li>▶ is more difficult to install than matting;</li> <li>▶ has to be laid down in strips, small patches or tiles (to avoid air pockets);</li> <li>▶ frequently requires an edge-sealing compound to be applied to prevent curling of the edges; and</li> <li>▶ (when abrasive) has to be steam cleaned or brushed (it cannot be mopped).</li> </ul>	<p>Heavy duty grades: suited to ramps, loading platforms, steps and ladders.</p> <p>Intermediate grades: suited to commercial and light industrial settings, where drainage and scraping are not of concern.</p> <p>Lighter grades suited for pool and shower areas.</p>
<p><b>Wall-to-Wall Flooring</b></p>	<p>Anti-slip surface fixed permanently to the floor</p> <p>Consists of thin rubber or vinyl sheets. Additional slip-resistance can be achieved by giving it an abrasive quality.</p>	<p>Abrasive quality is achieved by embedding particles of silicone carbide or aluminum oxide in the sheets. The particles stay below the surface of sheet until weight is applied. When weight is applied the particles protrude to provide abrasive slip resistance.</p> <p>Wall-to-wall flooring:</p> <ul style="list-style-type: none"> <li>▶ can be mopped (because the surface is selectively abrasive);</li> <li>▶ can be coved around walls and around irregularities like drain (because it is pliable);</li> <li>▶ can be treated at the seams to provide a watertight seal (hence, can be applied to provide a continuous watertight membrane that is hygienic and easy to keep clean); and</li> <li>▶ typically require professional installation.</li> </ul>	<p>Suited for areas where wet surfaces are common and the floors are cleaned often for hygienic purposes.</p>
<p><b>Coatings</b></p>	<p>Coatings are paint-like substances that provide textured or abrasive surfaces.</p>	<p>Coatings:</p> <ul style="list-style-type: none"> <li>▶ are available in various grades – including grease resistant;</li> <li>▶ can be applied in a variety of thickness by adding more coats;</li> <li>▶ tend to be the least costly of the anti-slip surfaces; and</li> <li>▶ are the least durable of the anti-slip surfaces.</li> </ul>	<p>Best suited to relatively moisture-free and grease-free work spaces.</p>

### 6e. Co-efficient of Friction Hazards and Controls

Ineffective co-efficient of friction (ratio of force that maintains contact between an object and a surface and the frictional force that resists the motion of the object) for walking and work surfaces pose a slip hazard and can be controlled through various methods.

Hazard Source	Description of Hazard	Method of Control
<b>Surface Design</b>	Surfaces that present an uneven co-efficient of friction.	<p>Redesign surface to provide a uniform co-efficient of friction.</p> <p>The hazard of walking surfaces that are unavoidably wet or greasy can be controlled by:</p> <ul style="list-style-type: none"> <li>▶ removing the substance;</li> <li>▶ roughening the surface;</li> <li>▶ covering it with grating or matting; and/or</li> <li>▶ appropriate footwear.</li> </ul>
<b>Ice</b>	Snow and ice adhering to walking surfaces drastically reduce their coefficient of friction.	<p>Controls for this hazard include:</p> <ul style="list-style-type: none"> <li>▶ plowing and shoveling;</li> <li>▶ de-icing;</li> <li>▶ salting;</li> <li>▶ and sanding.</li> </ul> <p>Salt is widely used as an ice remover. Salt has the capacity to melt ice because a solution of salt and water has a freezing point considerably lower than water itself. However, it is no longer effective for this purpose at temperatures below minus 4 degrees centigrade (25 degrees Fahrenheit).</p> <p>Sand is a good alternative to salt since it creates a surface with high friction or traction. Blends of salt and sand are widely used.</p> <p>Chemical de-icing products are sometimes used on sidewalks.</p>
<b>Footwear</b>	Footwear soles made of incorrect material or a worn surface condition will have a reduced coefficient of friction.	<p>The correct sole material is required for the surface condition.</p> <p>Synthetic rubber or neoprene soles are:</p> <ul style="list-style-type: none"> <li>▶ suitable for most surfaces, wet or dry,</li> <li>▶ NOT suitable for oily or greasy surfaces.</li> </ul> <p>Leather soles are:</p> <ul style="list-style-type: none"> <li>▶ best suited for wet or greasy surfaces,</li> <li>▶ hazardous on dry, smooth concrete and tile.</li> </ul> <p>Hard rubber soles are:</p> <ul style="list-style-type: none"> <li>▶ suited for greasy concrete or wood surfaces,</li> <li>▶ not well suited for tiles, wood and concrete (either wet or dry).</li> </ul> <p>Soft rubber soles are:</p> <ul style="list-style-type: none"> <li>▶ best suited for dry surfaces of most types.</li> </ul> <p>Crepe:</p> <ul style="list-style-type: none"> <li>▶ performs well on rough surfaces (however, only a small proportion of slips happen on surfaces that are either dry or rough).</li> </ul>

## 6f. Trip Hazards – Control Through Design

Category	Design Principles
<b>Work Design</b>	<p>Design work tasks to eliminate:</p> <ul style="list-style-type: none"> <li>▶ tasks that require workers to carry objects in a way that their vision is obstructed; and</li> <li>▶ tasks that require workers to travel up and down stairs while carrying objects with two hands (hence, the handrail cannot be used).</li> </ul>
<b>Work Space Design</b>	<p>Design work spaces such that:</p> <ul style="list-style-type: none"> <li>▶ effective and safe storage is available for tools, equipment, etc.;</li> <li>▶ electrical floor receptacles are located away from corridors, isles and walkways;</li> <li>▶ telephone cords at the sides of desks are clipped or tied out of the way;</li> <li>▶ corners and intersections where vision is obstructed is outfitted with convex mirrors so that oncoming traffic can be seen; and</li> <li>▶ aisles are designed to fully accommodate traffic.</li> </ul>
<b>Stairway Design</b>	<p>Control hazards on workplace stairs through uniform design (e.g., ensures that the design of the stairs is consistent throughout so that users do not encounter unanticipated features).</p> <p>Design stairways that:</p> <ul style="list-style-type: none"> <li>▶ have a run of between 255-355 mm (10 -14 in)</li> <li>▶ have a rise of between 125-200 mm (5 -8 in)</li> </ul> <p>[Ontario Building Code, s.3.4.6.7(1) and (2)]</p> <p>Other principles of good stairway design include:</p> <ul style="list-style-type: none"> <li>▶ ramps instead of single risers</li> <li>▶ handrails on both sides of a ramp and a stairway (if stairs are more than 1100mm in width) :             <ul style="list-style-type: none"> <li>– designed to be between 865-965 mm high, measured vertically from a line drawn through the outside edges of the stair nosing or from the surface of the ramp</li> </ul> </li> <li>▶ intermediate handrails (handrails in the middle of the staircase) on stairs with a width of more than 2.2 meters (88 inches);</li> <li>▶ handrail clearance of at least 5 centimeters (2 inches);</li> <li>▶ treads with a good coefficient of friction:             <ul style="list-style-type: none"> <li>– through use of vinyl or rubber-tractioned surfaces, non-slip strips, slip-resistant epoxy, or grooving; and</li> </ul> </li> <li>▶ good illumination that enables users to clearly discern tread noses:             <ul style="list-style-type: none"> <li>– including supplementary illumination to eliminate shadows.</li> </ul> </li> </ul> <p>[Ontario Building Code, s.3.4.6.4]</p> <p>Note: Many Building Codes make a number of these design features mandatory. Refer to the Building Code in your jurisdiction for specific information.</p>
<b>Ramp Design</b>	<p>Principles of good ramp design include:</p> <ul style="list-style-type: none"> <li>▶ ramps no shorter and no narrower than 1 metre (3 feet) so that they are readily detectable;</li> <li>▶ landings at the top, on either side of doors onto the ramp, and at intermediate levels with a depth of at least 1.67 x 1.67 meters (5.5 x 5.5 feet);</li> <li>▶ Ramps must be equipped with handrails on both sides. For detailed handrail specifications, refer to the Ontario Building Code, s. 3.8.3.4</li> <li>▶ Ramps must have a wall or guard on both sides. Where a guard is provided, it must meet the specifications of the OBC, s. 3.8.3.4</li> </ul> <p>[Ontario Building Code, s.3.8.3.4]</p> <p>Note: Many Building Codes make a number of these design features mandatory. Refer to the Building Code in your jurisdiction for specific information.</p>

### 6g. Trip Hazards – Control Through Programs and Systems

Type of Program/ System	Description
<b>Housekeeping Program</b>	<p>Housekeeping is a control at the source of the safety hazards caused by improper storage/placement of tools, cords and hoses, falling objects and debris. Housekeeping keeps walking and work surfaces clear of trip and fall hazards.</p> <p>A good housekeeping program identifies and assigns responsibilities for day-to-day clean-up, waste disposal and removal of unused materials. It also assigns responsibilities for inspection to ensure that all is kept in good order</p> <p>Examples of practices to be included in a good housekeeping program include:</p> <ul style="list-style-type: none"> <li>▶ securing cords (including power tool cords and extension cords);</li> <li>▶ returning all tools, cords and equipment to the appropriate storage place when work is complete;</li> <li>▶ ensuring spills are cleaned up immediately;</li> <li>▶ ensuring obstacles that develop are removed right away;</li> <li>▶ keeping stairs and walkways clear of debris;</li> <li>▶ cleaning and repairing stairway lighting;</li> <li>▶ keeping file drawers and other drawers closed; and</li> <li>▶ ensuring that material, tools and equipment are in their proper places.</li> </ul>
<b>Preventive Maintenance Program</b>	<p>The Occupational Health and Safety Act places a duty on employers to maintain equipment, materials and protective devices in good condition. An effective preventive maintenance program will enable employers to fulfill this duty.</p> <p>With regards to slips/falls and loss of balance, a preventive maintenance program controls potential hazards caused by surface defects and equipment failures by keeping surfaces and equipment in safe working order. Programs that are well developed and consistently followed can prevent the gradual breakdown or sudden failure of surfaces and equipment.</p> <p>Preventive maintenance programs:</p> <ul style="list-style-type: none"> <li>▶ include maintenance schedules and records of maintenance work;</li> <li>▶ include procedures to ensure that spare parts are available;</li> <li>▶ systematically plan for the maintenance of floors, stairs, ramps, ladders, and scaffolds;</li> <li>▶ address workplace lighting concerns;</li> <li>▶ may be responsible for snow and ice removal (if not addressed through a housekeeping program); and</li> <li>▶ include responsibility for either: <ul style="list-style-type: none"> <li>– carrying out preventive maintenance on powered equipment; or</li> <li>– ensuring (and verifying) that preventive maintenance on powered equipment is carried out by the supplier.</li> </ul> </li> </ul>
<b>Warning Systems</b>	<p>Hazards that cannot be eliminated at the source can be controlled along the path from the hazard to the worker through a warning system that uses highlighting and signaling practices.</p> <p>Through a warning system, hazards are made visible so that they can be anticipated or avoided. Examples of practices used to manage hazards through a warning system include:</p> <ul style="list-style-type: none"> <li>▶ using visual cues to indicate a one-step riser, speed bump or other trip hazards such as: <ul style="list-style-type: none"> <li>– direct lighting;</li> <li>– handrails;</li> <li>– warning signs; or</li> <li>– a colour contrast with the surrounding area.</li> </ul> </li> <li>▶ marking floor receptacles with cones (until they can be capped);</li> <li>▶ outlining the borders of aisles with strong, contrasting colours (so that there can be no mistake that their purpose is traffic, not storage);</li> <li>▶ signaling locations where a conveyor system can be safely crossed; and</li> <li>▶ posting signs and barriers to warn workers about temporary slip hazards.</li> </ul> <p>(Refer to the section labelled Warning Systems – A Guide to the Design, Selection and Use of slips/falls and loss of balance hazard signs, symbols and colours.)</p>

## 6h. Slips/Trips Hazards – Control Through Warning Systems

### Why Use Warning Signs and Symbols for Falls?

Through training, employees can learn to identify slips/falls and loss of balance hazards. They can also learn about control measures. Warning signs, symbols and messages can re-enforce what they have learned and the control measures by acting as a reminder and awareness tool.

#### FALL HAZARD

in Chinese	下墜 / 跌絆的危險
in Farsi	خطرافتادن
in French	Risqué de tomber
in Italian	Pericolo di caduta



You could write the words "Fall Hazard" in every language in the world to communicate the existence of an identified fall hazard in a workplace. Yet, a single picture, as shown above, means the same thing in every language. The picture is considered an intelligible form of visual communication.

### For What Type of Slips/Trips Hazards Might We Use Warning Signs and Symbols to Communicate a Hazard?

Posting a well-designed sign can help people recall training instructions and serve as a reminder to follow control instructions. Some examples of fall hazards that it may be helpful to identify through symbols and signs include:

- ▶ Falls from ladders (steps and extension ladders);
- ▶ Falls from piled materials (e.g., skids, boxes);
- ▶ Falls from stairs;
- ▶ Falls from scaffolds, stagings, walkways, platforms, ramps, etc.;
- ▶ Falls from stationary vehicles;
- ▶ Falls from buildings, roofs, bridges, trestles;
- ▶ Falls to lower level (e.g., openings such as a pit);
- ▶ Falls to walkway or working surfaces (e.g., tripping over objects); and
- ▶ Falls on same level (e.g., slips and falls due to wet surface).

### How Might We Use Words to Create a Warning Sign?

Words such as **ladder**, **walkway** and **tripping** can be selected to create signs and symbols illustrating the identified hazards or instructions for its control. Once displayed, these signs and symbols can:

- ▶ provide information or warnings;
- ▶ show mandatory rules; or
- ▶ prohibit unsafe actions.



**How Do We Design Fall Hazard Signs and Symbols?**

There are international and national conventions for using signs.

The CSA (Canadian Standards Association) and ANSI (American National Standards Institute) provide detailed specifications for the design of signs, colours, shapes and pictograms or symbols. A summary of the CSA standard appears in the table below.

**Why Should We Provide Training If We Are Using Signs and Symbols?**

While signs and symbols are an effective means for providing hazard warning and information, they do not substitute for control measures such as safe procedures. As well, the law requires the employer to provide instruction and training to workers.

**Where Do We Post Signs and Symbols?**

Once you have conducted an analysis of situations where a fall is likely to occur at your workplace, if you are unable to eliminate the hazard at the source, a sign and symbol program can be selected for implementation.







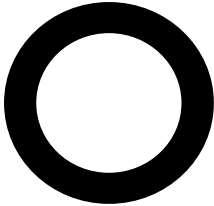
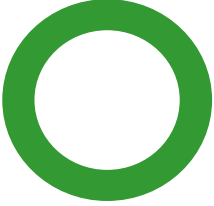

Warning signs should be posted at a point beyond which a fall hazard exists.

Other signs, such as prohibition, regulatory or information signs can be posted at appropriate locations where they are most likely to come to the attention of workers.

**Are There Any Ready Signs That I Could Use Now?**

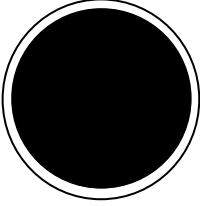
IAPA has developed a collection of fall hazards warning signs that you can consider using (see page 43). Depending on the analysis of the fall hazards in your workplace, you may decide to follow the standards listed in this guide and create other signs. Safety Supply companies are also a good source for signs. The WSIB offers signs and posters for certain situations (ex. Ladder safety).

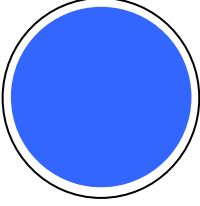
**Signs and their Meaning**

Sign	If Colour is:	Then Meaning is:	Looks Like:	Example:
	Green	Permission		 Pedestrians Allowed
Regulatory Circle				
	Red	Prohibition		 No Climbing
	Black	Mandatory (by CSA Standards)		 Slip Resistant Shoes Must be Worn
	Blue	Mandatory (by ISO Standards)		 Slip Resistant Shoes Must be Worn

**6. Hazard Control Information – Slips/Falls and Loss of Balance (from same elevation and heights)**

Sign	If Colour is:	Then Meaning is:	Looks Like:	Example:
 Information Rectangle	Green	Emergency (e.g., First Aid and/or Safety Equipment)		 Fall Protection Equipment Storage
	Blue	General Information		 Rescue Equipment
 Warning Triangle	Black Triangle Yellow Fill	Caution		 Frequent Trip and Fall Area
	White Traingle Red Fill	Danger		 Entering will Result in Serious Injury

**Samples of Signs**



## 6i. Walking Surfaces – General Controls

	Controls via Administration	Controls via Worker
<b>General Controls</b>	<p>Establish and enforce procedures for:</p> <ul style="list-style-type: none"> <li>▶ immediate clean up of spills;</li> <li>▶ waste disposal;</li> <li>▶ parts and equipment storage;</li> <li>▶ ladder and scaffold safety; and</li> <li>▶ the reporting and correction of slip and trip hazards.</li> </ul> <p>Post warning signs in slippery areas.</p> <p>Review accident records periodically. (Where and how have slips and falls occurred? Have conditions and contributing causes been addressed?)</p> <p>Provide permanent access to high places which must be reached regularly.</p>	<p>Everyone should take the following precautions:</p> <ul style="list-style-type: none"> <li>▶ walk at a safe speed (do not run);</li> <li>▶ watch where you are going;</li> <li>▶ change direction carefully;</li> <li>▶ use flashlight or extension light in dim or unlit areas; and</li> <li>▶ be alert at all times.</li> </ul>
<b>In-plant Controls</b>	<p>Install non-slip surfaces especially around machinery and equipment where spills may occur, on stairs and ramps and in canteens and aisles.</p> <p>Provide duckboards or other non-slip footing in frequently wet areas.</p> <p>Provide proper lighting, particularly on stairs.</p> <p>Repair or replace worn or damaged stair treads.</p> <p>Install drip pans.</p> <p>Provide proper storage facilities.</p>	<p>Everyone should:</p> <ul style="list-style-type: none"> <li>▶ wear clothing that fit properly and are in good repair;</li> <li>▶ wear suitable footwear;</li> <li>▶ store heavy objects in low places;</li> <li>▶ not carry loads that obstruct their view; and</li> <li>▶ refrain from horseplay.</li> </ul>
<b>Outside Area Controls</b>	<p>Loading dock: mark the edges with yellow warning lines. Caution everyone to watch for the edge.</p> <p>Keep stairs, ramps and walkways clear and in good condition.</p> <p>Maintain parking lots – use sand or salt on icy patches in the winter.</p>	<p>Never jump from a loading dock – use the stairs.</p>
<b>Office Controls</b>	<p>Make sure that there are no turned up or worn patches in carpets.</p> <p>Place telephone cords, cables, etc. out of the way of traffic.</p> <p>Arrange furniture so that it does not create an obstacle.</p> <p>Apply non-slip coatings to uncarpeted floor areas (e.g., in washrooms).</p>	<p>Keep desk and file drawers closed when not in use.</p>

### Checklist for Walking and Working Surfaces

- |  |   |
|--|---|
| <input type="checkbox"/> Ladders (secure, condition)         | <input type="checkbox"/> Loading dock (surface condition, work practices)         |
| <input type="checkbox"/> Scaffolds (secure, condition)       | <input type="checkbox"/> Parking lot (condition)                                  |
| <input type="checkbox"/> Ropes/cables (condition)            | <input type="checkbox"/> Office (carpet, telephone cords, equipment, power cords) |
| <input type="checkbox"/> Stairs (lighting, clear, condition) | <input type="checkbox"/> Reporting procedures posted/enforced                     |
| <input type="checkbox"/> Floors (holes, spills, clutter)     | <input type="checkbox"/> Warning signs posted/barriers erected                    |
| <input type="checkbox"/> Projecting machine parts            | <input type="checkbox"/> Written procedures for safe walking/working surfaces     |

## **7. Hazard Information – Ministry of Labour Bulletins**

**MOL Engineering Data Sheet 2-04:  
Fixed Access Ladders**

**MOL Engineering Data Sheet 2-05:  
Railings and Toeboards**

## 7a. MOL Engineering Data Sheet 2-04: Fixed Access Ladders

*Source:* Ontario Ministry of Labour Bulletins

*Ontario Ministry of Labour – Occupational Health and Safety Division – Industrial Health and Safety Branch*

### 1. Legislative Requirements

- 1.1 **Section 19** of the Regulations for Industrial Establishments states: Where frequent access is required to equipment elevated above or located below floor level, permanent platforms shall be provided with access by a fixed stair or access ladder.
- 1.2 **Section 18 (1)** of the regulation states: An Access ladder fixed in position shall,
  - (a) be vertical;
  - (b) have rest platforms at not more than nine metre (30 ft) intervals;
  - (c) be offset at each rest platform;
  - (d) where the ladder extends over five metres (16 ft) above grade, floor or landing, have a safety cage commencing not more than 2.2 metres (7 ft) above grade and continuing at least ninety centimetres (36 inches) above the top landing with openings to permit access by a worker to rest platforms or to the top landing;
  - (e) have side rails that extend ninety centimetres (36 inches) above the landing; and
  - (f) have rungs which are at least fifteen centimetres (6 inches) from the wall and spaced at regular intervals.
- 1.3 **Section 18 (2)** of the regulation also states that: Subsection (1) does not apply to an access ladder on a tower, water tank, chimney or similar structure which has a safety device which will provide protection should a worker using the ladder fall.

### 2. General

- 2.1 Fixed access ladders shall be designed, constructed, installed and maintained so as not to endanger a worker and shall be capable of withstanding all loads to which they may be subjected.
  - 2.1.1 Structural design, including attachment methods, should be performed by a Professional Engineer.
  - 2.1.2 The minimum design live load imposed by persons shall be two loads of 1.1 KN (250 lb) each concentrated between any two consecutive attachments. Each rung in the ladder shall be designed for a single concentrated live load of 1.1 KN (250 lb) minimum.
  - 2.1.3 Other loads, such as concentrated loads, loads due to ice, wind, rigging or impact, and dead loads, shall be considered in the design.

- 2.1.4 A safety factor of at least 4:1 shall be applied in designing components for normal usage and at least 10:1 for components supporting fall-arrest systems.
- 2.2 All parts and surfaces of fixed ladder installations shall be free of sharp edges, burrs or other details that may be hazardous to the person using the ladder.
- 2.3 Prevention of unauthorized access may be achieved only by methods that do not compromise the safety or structural integrity of the ladder.
- 2.3.1 For example, a smooth panel may be locked over the lower rungs.
- 2.3.2 The bottom portion of an existing ladder shall not be cut off for security purposes.
- 2.4 Design, condition and surface finish of rungs and side rails must permit secure foothold and handhold. Avoid highly polished surfaces which may become slippery, especially when wet. Avoid designs having rungs with sloping upper surfaces (a condition which may occur when a step-ladder is converted into a fixed ladder).
- 2.5 Where access is required to Heating, Ventilating and Air Conditioning (HVAC) equipment or other equipment mounted on a roof or slung under a ceiling, the building design should ensure safe means of access for service personnel.
- 2.6 Roof access hatches served by fixed ladders must be at least 550 mm (21 5/8 in.) by 900 mm (2ft 11 in.) on buildings more than 3 stories in building height, where the slope of the roof is less than 1 in 4.
- 2.7 When oversized clothing or equipment is anticipated (for example, self-contained breathing apparatus), the ladder design should take such needs into consideration. However, dimensional extremes should be avoided to ensure that the ladder remains suitable for normal use.
- 2.8 Materials of construction shall be compatible with intended conditions of use. For example:
- aluminium ladders must not be used in a caustic environments
  - ladders made of dissimilar metals should be protected against deterioration due to galvanic electrolytic corrosion
  - wooden ladders should not be used in humid environments, or should be protected against deterioration from exposure to moisture



- 2.9 If the distance from the top of a parapet to the roof-top exceeds one rung-space (i.e. max. 300 mm or 12 inches) a means of climbing to and from the top of the parapet should be provided.
- 2.10 Fixed ladders should not be located in areas where the atmosphere creates or contributes to unsafe conditions. For example:
  - where ice may build up or steam may condense on a ladder
  - where oil or grease-laden air is present, such as cooking areas in commercial kitchens

### **3. Rungs**

- 3.1 The top of the uppermost rung of a ladder should be level with the top of the access/egress level or landing platform served by the ladder. Where there is a parapet, if the parapet is cut to permit passage through it, the access/egress level will be the roof. If the parapet is continuous, the access/egress level will be the top of the parapet.
- 3.2 Rungs shall have a non-slip surface.
- 3.3 To accommodate functional requirements or additional safety requirements, dimensions which exceed the minimum specified dimensions in Figures 1, 2 and 3 may be used, provided sizes are increased from the minimum specified sizes to maintain the same factor of safety. In the design example following (Fig. 1, "Typical Steel Access Ladder"), increasing the inside clear width of rungs from 400 mm (16") to 600 mm (24") would require an increase in the rung diameter from 20 mm (3/4") to 25 mm (1").

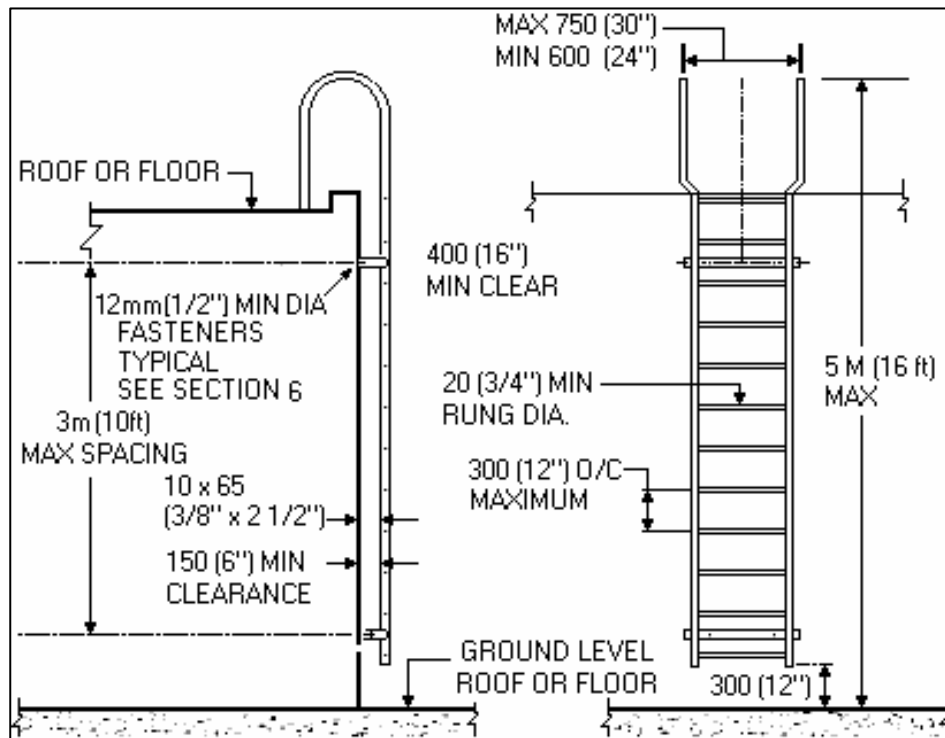

**FIG. 1: Typical Steel Access Ladder**  
General Arrangement – Cage not Required

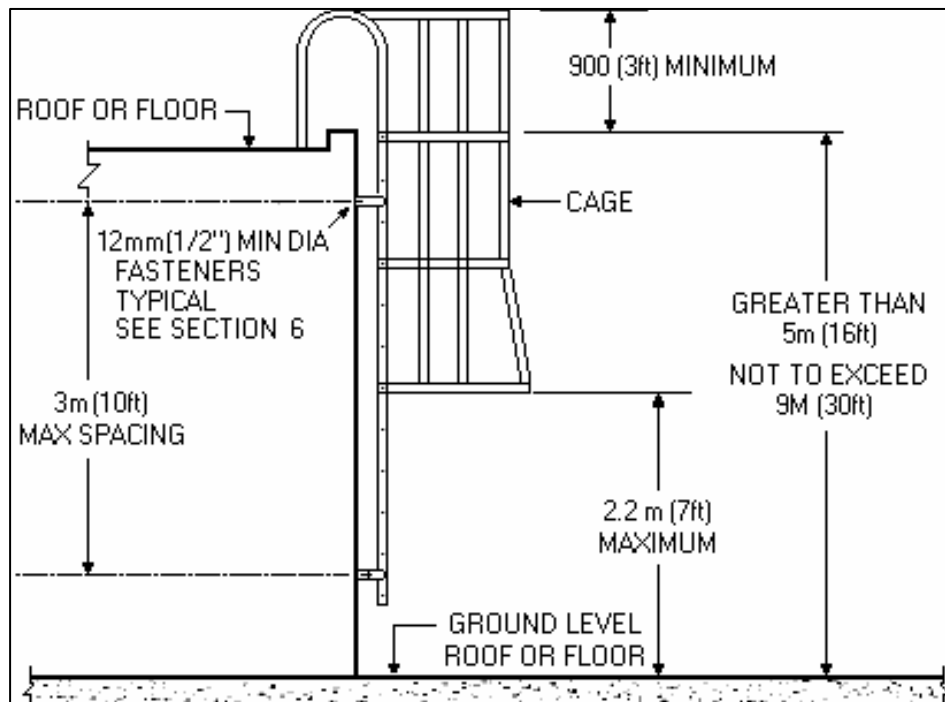

**FIG. 2: Typical Steel Access Ladder**  
General Arrangement – Cage Required

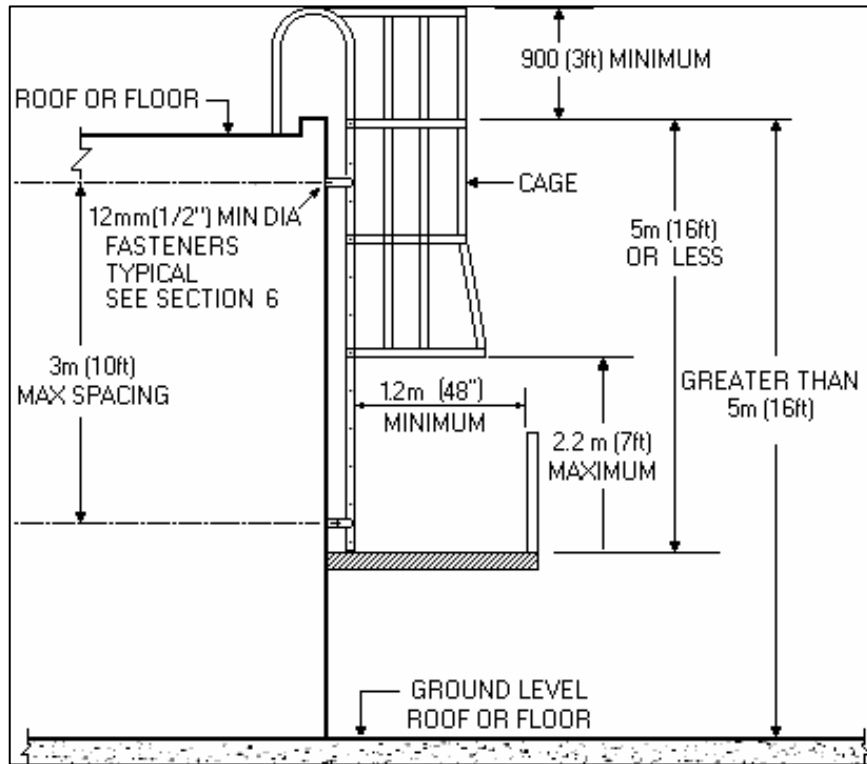

**FIG. 3: Typical Steel Access Ladder – Elevated Access**  
 General Arrangement – Cage Required for Wide Landings  
 [Ref. Section 5.1.2]

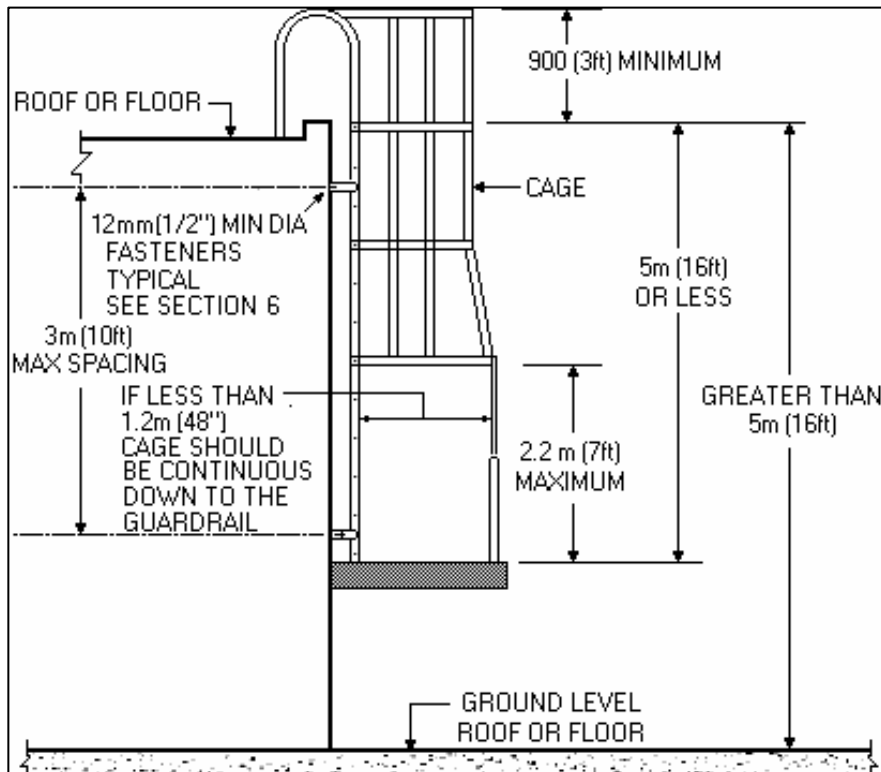

**FIG. 4: Typical Steel Access Ladder – Elevated Access**  
 General Arrangement – Cage Required for Narrow Landings  
 [Ref. Section 5.1.2]

#### **4. Side Rails**

- 4.1 Any shape of side rails may be used that provides a uniform gripping surface for the hands of workers using the ladders, as long as the shape permits a power grip.
  - 4.1.1 Side rail shapes that do not permit a power grip shall not be used.
  - 4.1.2 The same shape of side rails shall be maintained for all ladders in the same length of climb.
- 4.2 The minimum sizes (cross-section) of side rails recommended in this section (4.2) are based on satisfying the design criteria of section 2.1, assuming the maximum spacing of supports specified in section 6.2.4 below.
  - 4.2.1 For different design loads or support spacing, the minimum size of side rails shall be adjusted in accordance with recognized design practice.
  - 4.2.2 The same size (cross-section) of side rails shall be maintained for all ladders in the same length of climb.
  - 4.2.3 The minimum size (cross-section) recommended for a steel ladder (subject to normal atmospheric exposures) is 10 mm x 65 mm (3/8" x 2½") solid flat-bar stock.
  - 4.2.4 For different materials, the minimum recommended size shall be adjusted in accordance with recommended design practice.
- 4.3 Where it is not practicable to have fixed extensions of side rails above a landing, equivalent provisions shall be arranged. Extensions integrated into guardrails, telescoping side rails, extensions incorporated into roof hatches, etc., may be accepted by the Ministry of Labour. CENTRE-POST EXTENSIONS ARE NOT CONSIDERED ACCEPTABLE.

#### **5. Safety Cages**

- 5.1 With an elevated access, a cage shall be provided where the top of the ladder is higher than five metres (16 feet) above ground level, floor or roof, even if the length of the climb is less than five metres (Fig. 3).
  - 5.1.1 An elevated access from a platform having 1.2 metres (48 inches) (or more) clearance between the ladder and any adjacent guard rail, may utilize a standard cage (as per Fig. 3).
  - 5.1.2 An elevated access from a platform having less than 1.2 metres (48 inches) clearance between the ladder and any adjacent guard rail should have a cage continuous with the guardrail on the sides(s) with clearance less than 1.2 metres (48 inches) (Fig. 4).
- 5.2 Cages should be provided with horizontal hoops or bands to help prevent or arrest the fall of a worker.

- 5.3 Cages should not be less than 680 mm (27") in width and should extend not less than 680 mm (27") and not more than 760 mm (30") from the centre-line of the rung (measured on the climbed side of the ladder, horizontally and perpendicular to the rung). These restrictions do not apply to the bottom flare of cages.
- 5.4 The insides of cages should be free of obstructions.
- 5.5 Cages must be designed to withstand all loads to which they may be subjected.

**6. Attachment and Anchoring**

- 6.1 Structural soundness of the wall, member or piece of equipment to which the ladder is to be attached shall be confirmed by a competent person, prior to installation of the ladder.
- 6.2 Attachment method (e.g., through-bolting, anchoring, welding, etc.) must be rated for the intended structural service and for the type of wall, member or piece of equipment.
  - 6.2.1 Expansion anchors of all descriptions should be avoided with masonry walls. (Anchor manufacturers' pull-out ratings are invariably given for poured concrete walls; these ratings cannot be reliably attained in masonry.)
  - 6.2.2 Through-bolted connections (or an equivalent) shall be used for masonry walls and other walls for which there is no anchor manufacturer's pull-out rating. Generally, through-bolted connections should be used wherever practicable.
  - 6.2.3 Attachment and anchor bolts shall have a minimum diameter of 12 mm (½ inch).
  - 6.2.4 The maximum spacing of attachment points for a steel ladder with side rails shall be three metres (10 feet). For different materials or extra loads, this maximum spacing shall be adjusted in accordance with recognized design practice.
- 6.3 To provide an improved margin of safety, there should be two means of anchoring the top of the ladder. This may be accomplished by fastening the side rail extension above the top of the access/egress level to the structure, building or equipment.
- 6.4 Modifications to the attachment of the ladder to the structure, building or equipment must be approved by a professional engineer.

**7. Safety Platforms**

- 7.1 Suitable safety platforms should be provided along a ladder where worker activity is anticipated and where lack of such a platform would cause a significant additional hazard for workers. For example:
  - at the top of a ladder on a tower or similar structure where work of significant duration can be anticipated (such as gathering information on emissions)
  - on a roof access ladder, just under the roof hatch, where it can be anticipated that workers encumbered with tools and/or supplies will need to put them down before unlocking the work hatch
- 7.2 Rest platforms (per section 1.2 b), above may be used for this purpose, where practicable.
- 7.3 Minimum total depth of the platform (from climbed side of ladder to guardrail) should be 760 mm (30 inches) and the minimum width of the platform should be 760 mm (30 inches).
- 7.4 Self-closing safety gates should be provided on platforms next to a ladder, whenever worker activity near the ladder can be foreseen.

**8. Inspection**

- 8.1 Fixed access ladder installations shall be periodically inspected for rust, corrosion and structural integrity and be maintained in a good condition that is not likely to endanger any worker. These inspections should be conducted at least once a year.
- 8.2 Records of inspections and maintenance of fixed access ladder systems should be maintained.

**9. References**

- ANSI A14.3 – 2002 American National Standard, "Ladders, Fixed Safety Requirements"
- USDOL-OSHA 1910.27 Fixed Ladders
- O.B.C. – 1990 Ontario Building Code

This Engineering Data Sheet is issued by the Ministry of Labour, Occupational Health and Safety Branch, as a guide only and does not constitute legal compliance.  
The information contained in this document is subject to revision at any time.  
Please use discretion in interpreting these guidelines.

## 7b. MOL Engineering Data Sheet 2-05: Railings and Toeboards

Source: Ontario Ministry of Labour Bulletins

*Ontario Ministry of Labour – Occupational Health and Safety Division – Industrial Health and Safety Branch*

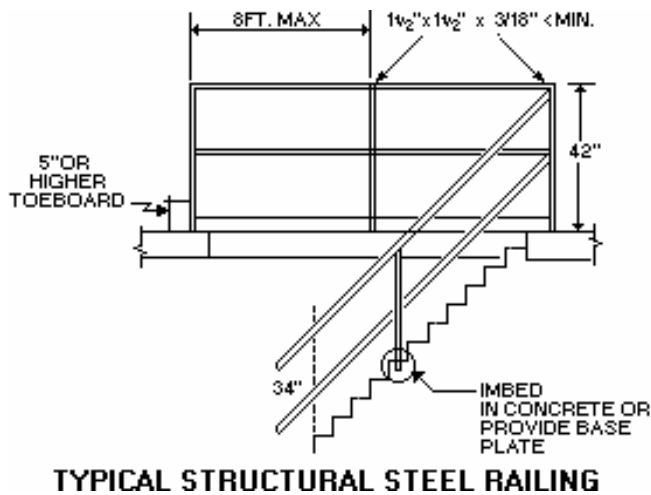
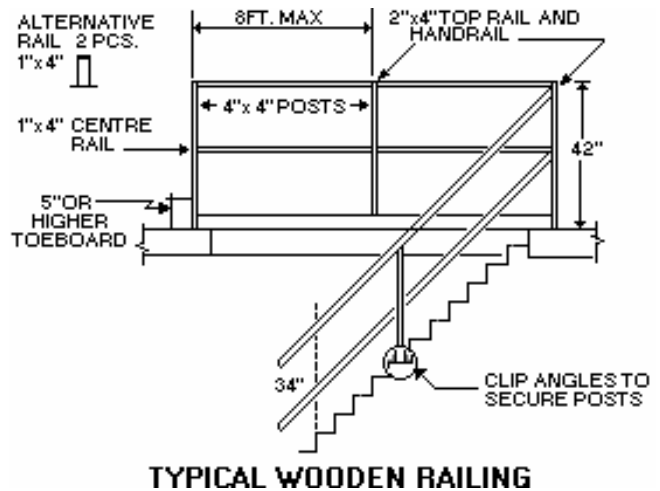
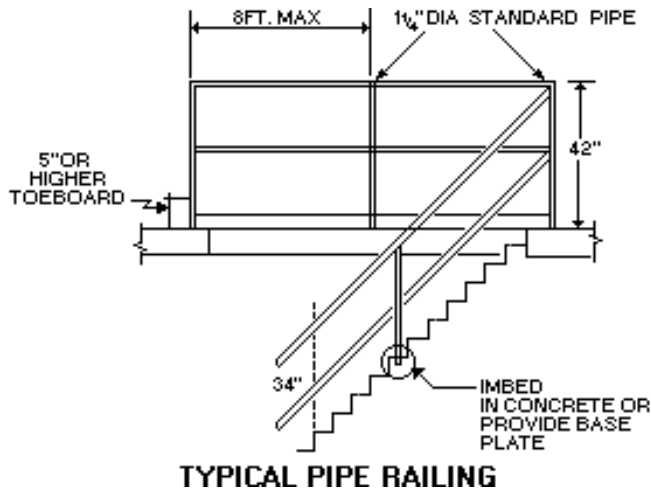

### Notes:

1. Guardrails to be securely anchored to floor. when used around hatchways, one or more sides may be hinged or in sockets.
2. Centre rail to be midway between floor and top rail. If space between floor and toe rail is filled in (solid or wire screen), toeboard and centre rail may be omitted.
3. If wire screen is used between floor and top rail, no. 12 g.a. or heavier wire, and not over 2" mesh is to be used.

This Engineering Data Sheet is issued by the Ministry of Labour, Occupational Health and Safety Branch, as a guide only and does not constitute legal compliance.

The information contained in this document is subject to revision at any time. Please use discretion in interpreting these guidelines.

## 8. Resources



### The Industrial Accident Prevention Association has:

- ▶ Fall Prevention programs
- ▶ Fall Prevention training
- ▶ Information Centre
- ▶ Best Practices in Fall Prevention
- ▶ Phone 1-800-406-IAPA (4272) – [www.iapa.ca](http://www.iapa.ca)



### The Workplace Safety and Insurance Board

- ▶ Help you analyze your injury record to determine claim costs and develop a prevention strategy based on your past experience.
- ▶ Phone: 1-800-663-6639 – [www.wsib.on.ca](http://www.wsib.on.ca)



### The Ministry of Labour

- ▶ Help you understand the legislation and reinforce the requirements.
- ▶ Phone: See blue pages of phone book for local MOL office [www.labour.gov.on.ca](http://www.labour.gov.on.ca).

You may contact any of these organizations and will be linked to the others as needed. We are partnering to co-ordinate and plan programs, activities and services that will meet your injury prevention needs.

### IAPA Products

- ▶ Inspecting Physical Conditions, Guidelines for Setting Standards
- ▶ Housekeeping At Work\*
- ▶ Walking and Working Surfaces\*
- ▶ Ladders\*
- ▶ Rolling Scaffolds\*
- ▶ Workplace Inspection Recording Form\*
- ▶ Injury Analysis Report\*

---

\* Download from [www.iapa.ca](http://www.iapa.ca)



# 9. References

For specific guidelines and references, refer to the following:

### **Occupational Health and Safety Act**

- ▶ Regulations for Construction Projects
- ▶ Regulations for Health Care and Residential Facilities
- ▶ Regulations for Industrial Establishments
- ▶ Regulations for Mines and Mining Plants
- ▶ Regulations for Roll-Over Protective Structures
- ▶ Regulations for Window Cleaning

### **Ministry of Labour Engineering Data Sheets and Alerts**

- ▶ Engineering Data Sheet 2-05, Railings and Toeboards
- ▶ Engineering Data Sheet 2-04, Fixed Access Ladders
- ▶ Hazard Alert – Davit Arm System Failure (ISSN 1195.5228)

### **Canadian Standards Association**

- ▶ Fall Arrest Systems: Practical Essentials (PLUS 1156)
- ▶ B651-04, Accessible design for the Built Environment
- ▶ CAN/CSA-Z195-02, Protective Footwear
- ▶ CAN/CSA-Z259.1-05 Body Belts and Saddles for Work Positioning and Travel Restraint
- ▶ CAN/CSA-Z259.11-05 Energy Absorbers and Lanyards
- ▶ CAN/CSA-Z259.12-01 (R2006) Connecting Components for Personal Fall Arrest Systems
- ▶ CAN/CSA-Z91-02 Health and Safety Code for Suspended Equipment Operations
- ▶ CAN/CSA-S269.2-M87 Access Scaffolding for Construction Purposes
- ▶ CAN/CSA-Z259.10-06 Full Body Harnesses
- ▶ CAN/CSA-Z321-96 Signs and Symbols for the Workplace (and R2001)
- ▶ CAN3-Z11-M81 (R2003) Portable Ladders
- ▶ Z259.2.1-98 (R2004) Fall Arresters Vertical Lifelines, and Rails
- ▶ Z259.2.2-98 (R2004) Self-Retracting Devices for Personal Fall-Arrest Systems

### **American National Standards Institute**

- ▶ ANSI Z359.1-1992 (R1999) Safety Requirements for Personal Fall Arrest Systems, Subsystems and Components

### **Construction Safety Association**

- ▶ Construction Safety Magazine, volume 9, number 3, Autumn 1998 call 1-800-781-2726

### **Canadian Centre for Occupational Health and Safety**

- ▶ PPE Care of Safety Belts, Harnesses and Lanyards
- ▶ Canadian Centre for Occupational Health and Safety-PPE Infogram K04 Safety Footwear

### **Safety and Health, September 1991**

- ▶ Anchorage Planning: The Key to Fall Protection

### **Underwriters Laboratory of Canada**

- ▶ CAN/ULC S555-01 – Fire and Emergency Service Technical Rescue Rope and Water Rescue Throw Rope and Associated Equipment

### **National Institute of Occupational Safety and Health**

- ▶ Criteria for a Recommended Standard: Emergency Egress from Elevated Workstations (1975). NIOSH Publication Number 76-128

### **Industrial Accident Prevention Association**

- ▶ Housekeeping at Work (available at [www.iapa.ca](http://www.iapa.ca))
- ▶ Inspecting Physical Conditions, Guidelines for Setting Standards – LPBA0140410
- ▶ Ladders (available at [www.iapa.ca](http://www.iapa.ca))
- ▶ Rolling Scaffolds (available at [www.iapa.ca](http://www.iapa.ca))
- ▶ Walking and Working Surfaces (available at [www.iapa.ca](http://www.iapa.ca))
- ▶ Workplace Inspection Recording Form (available at [www.iapa.ca](http://www.iapa.ca))
- ▶ Safety Signs and Colour at Work (available at [www.iapa.ca](http://www.iapa.ca))

### **Workplace Safety and Insurance Board**

- ▶ WSIB, Fact Sheet, Prevention, Slips and Falls, English #3129A(03/03)
- ▶ WSIB, Winter Slips and Falls, Alert!, Hazards at Work Series, January 2004

### **General References**

- ▶ Andrew C. Sulowski, Fall Arrest Systems – Practical Essentials
- ▶ Breaking the Fall, part 1, Accident Prevention Magazine, January/February 1997
- ▶ Breaking the Fall, part 2, Accident Prevention magazine, May/June 1997
- ▶ Cameron Taylor and Lee-Ann Jack, Slips, Trips and Falls, Occupational Health and Safety Canada, September-October, 1991
- ▶ Closing the Gait on Slips, Trips and Falls, Safety and Health Magazine, National Safety Council, June, 1990
- ▶ D2047-04, Standard Test Methods for Static Coefficient of Friction of Polish-Coating Flooring Surfaces
- ▶ Health and Safety Executive, Watch Your Step, Prevention of Slipping, Tripping and Falling Accidents at Work. ISBN #0 11 883782 6
- ▶ Jeffrey Elie, Anti-slip Products: Getting a Foothold on Safety, Occupational Health and Safety Canada, March-April, 1997
- ▶ The Work Environment, Volume 1, Chapter 12, Trip, Slip and Fall Prevention, William Marietta, 1991