

A GUIDE TO SAFETY IN THE METAL FABRICATION INDUSTRY

1ST EDITION

MARCH 2007

MANUFACTURING

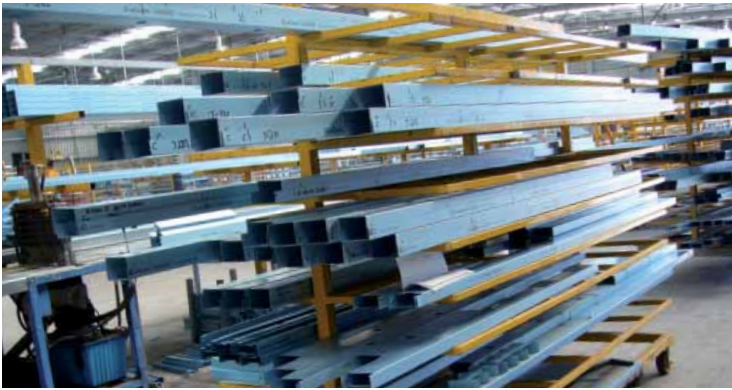

CONTENTS

INTRODUCTION	2	4. ENVIRONMENT	37
The legal framework	2	Plant layout	38
Consultation	3	Workplace traffic management	38
Information instruction and training	4	Noise	39
‘Reasonably practicable’ control measures	4	Housekeeping	40
How to use this guide	5	Lighting	41
1. MANUAL HANDLING	6	Temperature of workplace	41
Manual handling and musculoskeletal disorders ..	7	Protective clothing and equipment	42
Unloading raw materials	8	OTHER USEFUL GUIDANCE MATERIAL	43
Transport of materials on the shop floor (heavy) ..	10	ACKNOWLEDGEMENTS	44
Transport of materials on the shop floor (light) ..	12		
Manufacturing at workstations	14		
Die handling	16		
Packing stillages	18		
Loading and handling finished product	21		
2. HAND TOOL USAGE	23		
Angle grinding	25		
Welding	27		
3. GUARDING	31		
Power presses	34		
Brake presses	35		
Guillotines	36		

WorkSafe Victoria is a division of the Victorian WorkCover Authority.

The information presented in *A Guide To Safety in the Metal Fabrication Industry* is intended for general use only. It should not be viewed as a definitive guide to the law, and should be read in conjunction with the *Occupational Health and Safety Act 2004*.

Whilst every effort has been made to ensure the accuracy and completeness of the guide, advice contained herein may not apply in every circumstance. Accordingly, the Victorian WorkCover Authority (VWA) cannot be held responsible, and extends no warranties as to:

- the suitability of the information for any particular purpose;
- actions taken by third parties as a result of information contained in *A Guide To Safety in the Metal Fabrication Industry*.

This publication is protected by copyright. The Victorian WorkCover Authority (VWA) encourages the free transfer, copying and printing of this publication if such activities support the purposes and intent for which the publication was developed.

INTRODUCTION

This guide demonstrates WorkSafe Victoria's expectations on how to eliminate or reduce the risk of injury in the metal fabrication industry. Risk controls in this document have been implemented by industry in Victoria.

THE LEGAL FRAMEWORK

There is a legislative framework around controlling risk and consultation in the workplace. This guide shows ways to comply with the *Occupational Health and Safety Act 2004*.

Hazard identification

This guide identifies some tasks undertaken in the metal fabrication manufacturing industry that are hazardous and have resulted in injuries. However it is not a comprehensive list of all tasks that may pose a hazard.

Risk assessment

The guide does not replace requirements for risk assessment and controls, with the risk of an injury varying depending on the circumstances at each workplace. To ensure a reduction in injuries, employers should review risks and develop and implement a plan for controls in consultation with Health and Safety Representatives (HSRs) and employees.

Risk control

Risk controls are shown in this guide. It is the duty of an employer to carry out risk control under the *Consolidated Occupational Health and Safety Regulations 2007* that come into effect on 1 July 2007 replacing the current regulations.

These require the following actions to be taken:

1. eliminate the risk
2. if it is not practicable to eliminate the risk, reduce the risk so far as is practicable.

In either case, the risk can be controlled by any of the following ways:

- a. altering the workplace or environmental conditions
- b. altering the systems of work or
- c. changing the objects

A combination of controls often gives the best solution.

Consulting HSRs and employees, and trialling proposed solutions will determine if they are right for your workplace or if further modifications or different controls are required. It is necessary to monitor the success or otherwise of any controls implemented.

CONSULTATION

All employers are required to consult their employees, so far as reasonably practicable, on matters that may directly affect their health, safety or welfare. This includes consultation with an independent contractor and any employees of the independent contractor. Where there are elected HSRs, the employer must have a list of HSRs and any Deputy HSRs for each Designated Work Group (DWG) at the workplace that is displayed or otherwise be readily accessible to all employees.

Employers must consult HSRs on hazard identification, risk assessment, and risk control as well as any proposed changes in the workplace, plant, substances or work processes that could impact on the health, safety or welfare of workers.

This duty to consult recognises that employee input and participation improves decision-making on health and safety. Consultation between employers and employees is an essential part of effectively managing health and safety at work and is also a legal requirement and a valuable means of improving health and safety outcomes.

Through consultation, employers become more aware of hazards and OHS issues experienced by employees who in turn can also provide suggestions about how to solve OHS problems. Ongoing participation allows employees to contribute to determining how work can be done safely.

For more information on the duty to consult, please refer to the following WorkSafe publications:

- *Talking Safety Together and Consultation – A User's Guide*
- *Information for Employees on Health and Safety*
- *Employee Representation Guide*, and
- *Information for Health and Safety Representatives*

INFORMATION, INSTRUCTION AND TRAINING

Providing information, training and instruction cannot be the sole way of controlling the risk unless all other ways to control risk are not reasonably practicable. When training is provided, it must be task specific and competency based to ensure effectiveness. Supervisors must be competent and know how to best use specific risk controls. They must also be supported in this role. It is important that there is appropriate supervision of health and safety as well as production.

HSRs must have access to training, together with any Deputy HSRs. Employees in these roles have a legal entitlement to attend an initial five day OHS representatives course as well as an annual refresher course with the training provider of their choice.

You should always check the legislation referred to in this guide and make your own judgement about what action needs to be taken to ensure compliance with the law.

'REASONABLY PRACTICABLE' CONTROL MEASURES

The *Occupational Health and Safety Act 2004* explains what must be taken into account when deciding if something is 'reasonably practicable'. In general terms the factors are:

- the likelihood of the hazard or risk eventuating
- the degree of harm that would result if the hazard or risk eventuated
- what you know, or ought reasonably know, about the hazard or risk and any ways of eliminating or reducing that hazard or risk
- the availability and suitability of ways to eliminate or reduce the hazard or risk, and
- the cost of eliminating or reducing the hazard or risk.

It is expected that employers, HSRs, employees and WorkSafe inspectors will use this guide to form an opinion about suitable health and safety risk controls, under the test of 'reasonable practicability'.

Note: This guide should be used in conjunction with the Occupational Health and Safety Manual Handling Regulations, Occupational Health and Safety Plant Regulations and the relevant codes of practice. On 1 July 2007 the new consolidated regulations will come into effect, replacing the current regulations.

HOW TO USE THIS GUIDE

The red, amber and green format will help you identify high risk activities and assess your workplace to implement safer work practices. The rationale is simple. To reduce injury rates and compensation claims, high risk situations must be addressed.

If you are able to tick any of the boxes in the red bars which represent high risk activities then you should read further about the 'reduced risk' and 'preferred solution' controls detailed.

If high risk practices are followed in your workplace, you should determine if you can implement the solutions in the green column. If this isn't practicable, put in place the comparable practice in the amber column as a reduced risk or as an interim solution.

The amber and green solutions provide different options recognising that the tasks, and the risk, varies according to the specifics of a workplace. It is important that controls implemented address a task's risk factors.

HIGH RISK		TICK
The practices in the red boxes should not be used in workplaces; an employer who allows these practices to be used is likely to be in breach of OHS legislation		<input type="checkbox"/>
REDUCED RISK	PREFERRED SOLUTION	
The solutions in the amber column are less effective in reducing risk compared to those in the green column, and would be regularly reviewed with the aim to move towards higher order solutions (green)	The solutions in the green column are the most effective at reducing risk and should be regarded as the target for all workplaces	

Note: If you are able to demonstrate that an appropriate hazard identification and risk control plan process has been undertaken and you are able to verify that the 'reasonably practicable' test has been applied to the controls you implement, then control measures from the amber column may be deemed practicable.

1

MANUAL HANDLING

MANUAL HANDLING AND MUSCULOSKELETAL DISORDERS

UNLOADING RAW MATERIALS

TRANSPORT OF MATERIALS ON THE SHOP FLOOR (HEAVY)

TRANSPORT OF MATERIALS ON THE SHOP FLOOR (LIGHT)

MANUFACTURING PRODUCT AT WORKSTATIONS

DIE HANDLING

PACKING STILLAGES

LOADING AND HANDLING FINISHED PRODUCTS

MANUAL HANDLING AND MUSCULOSKELETAL DISORDERS

Manual handling

In the fabricated metals manufacturing industry, manual handling covers a wide range of activities such as transporting materials in the workplace, loading finished products for delivery, die handling, packing stillages, etc. Many of these tasks can result in musculoskeletal disorders (MSDs) and other types of injuries. However, not all manual handling is hazardous. Hazardous manual handling refers to manual handling with any of the following characteristics:

- repetitive or sustained application of force
- repetitive or sustained awkward posture
- repetitive or sustained movement
- application of high force
- exposure to sustained vibration
- manual handling of live persons or animals, or
- unstable or unbalanced loads or loads which are difficult to grasp or hold.

Musculoskeletal disorders

MSDs are sometimes referred to as 'sprains and strains'. It is a term used to describe a wide variety of injuries and diseases of the musculoskeletal system. This includes injuries to joints, ligaments, intervertebral discs and other structures in the back and injuries to joints, ligaments, tendons, muscles and nerves in the wrists, elbows, arms, shoulders, neck, abdomen (e.g. hernia), hips, knees and legs. Some of these conditions are sometimes described as repetitive strain injury (RSI), occupational overuse syndrome (OOS), cumulative trauma disorder (CTD) and work-related musculoskeletal disorder (WRMSD).

In the *Occupational Health and Safety (Manual Handling) Regulations 1999* these conditions are referred to as musculoskeletal disorders (MSD).

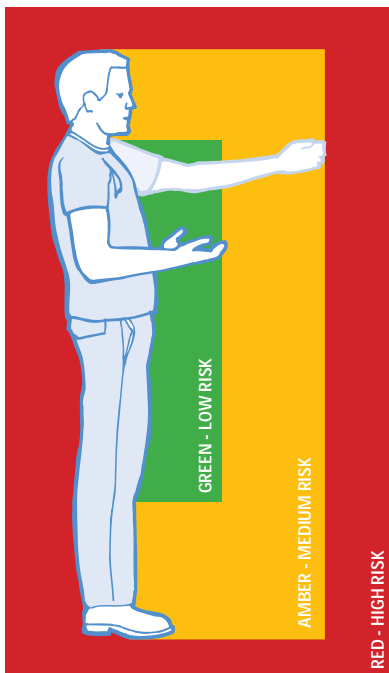

GENERAL PRINCIPLES

- Physical changes to workplace design, layout and plant are more effective than administrative risk controls.
- Postures, movements and forces known to be associated with MSD should be eliminated from the workplace where possible.
- No employee should be required to routinely work above their shoulder height, below their knees or at full reach distance.
- To accommodate different people and tasks, workstations should be quick and easy to adjust.

The best working zone is described as the area between the shoulders and knees

MANUAL HANDLING



UNLOADING RAW MATERIALS

When unloading raw materials, incidents have occurred where people use levers, such as metal bars to manually lever steel and other metal products off delivery vehicles. This practice is known as 'barring off'. By using purpose built cranes or forklifts, serious injuries can be prevented.

Does the task involve the following?

HIGH RISK	TICK
Barring off	<input type="checkbox"/>
Manually unloading with the use of high, sudden or unexpected forces	<input type="checkbox"/>
Working from heights without fall protection	<input type="checkbox"/>

REDUCED RISK

- Use an appropriately rated block and tackle on a jib arm or other such mechanical aids to unload raw material from ground level.

PREFERRED SOLUTION

- Use purpose built vehicles for small loads, ensuring the vehicle operator is trained in its safe use.
- Use a suitable mobile or overhead crane for bundled loads.



Onsite cranes assist in the unloading of raw materials.

REDUCED RISK

PREFERRED SOLUTION

- Use magnetic lifters.



Magnetic lifters rated to the correct working load can be used for unloading.

- Use a forklift with correct attachments for the task and load for bundled loads. The forklift operator must have the proper certification.

MANUAL HANDLING



TRANSPORT OF MATERIALS ON THE SHOP FLOOR - HEAVY

Heavy metal products such as steel that weighs 20 kg or more and/or longer than 2m, are moved in the workplace from the raw material storage area, through each production process, to the distribution of the final product.

The weight of these items is such that manual handling is not possible and the risks relate to the awkward postures when moving materials and being hit while transporting materials.

Does the task involve the following?

HIGH RISK		TICK
Manually handling heavy materials		<input type="checkbox"/>
Use of slings or chains not marked with SWL (safe working load) or in poor condition		<input type="checkbox"/>
Use of cranes by untrained operators		<input type="checkbox"/>
REDUCED RISK	PREFERRED SOLUTION	
<ul style="list-style-type: none"> • Use forklifts for transporting material. • This may introduce other hazards such as wide loads, traffic management issues and metal-on-metal issues on the forklift tynes. 	<ul style="list-style-type: none"> • Use bridge and gantry cranes with remote control or pendant control that can be operated from the best working zone, ensuring all equipment is tested and maintained. 	
	<p><i>Overhead crane assists in moving structural steel parts to the next workstation.</i></p> <ul style="list-style-type: none"> • No load should be suspended over, or travel over a person. 	

REDUCED RISK

PREFERRED SOLUTION



Overhead cranes must be rated to the correct SWL.



A purpose built device assists in moving heavy raw materials to the production line.

- Operators of bridge and gantry cranes are required to hold a certificate of competency or licence when the crane is remote or pendant controlled and capable of more than three powered operations or is cabin controlled.
- A licence can only be obtained by satisfying a competency assessment that has been conducted by an assessor.
- If the crane operator is required to exercise judgement in the selection of chains/slings or is required to do load calculations, then the operator is required to also obtain a certificate of competency covering dogging operations.
- In mid-2007 a licence covering both of these operations will be available for the first time.

MANUAL HANDLING



TRANSPORT OF MATERIALS ON THE SHOP FLOOR - LIGHT

Lighter metal products, e.g. those that weigh less than 20kg and are shorter than 2m are moved from the raw material storage area through each production process to the distribution of the final product.

Lifting or pushing and pulling these items involves the use of high force and sudden or unexpected forces, as these items can be heavy or long and they can stick together.

Does the task involve the following?

HIGH RISK	TICK
Lifting metal from storage areas that are above shoulder height or below knee height	<input type="checkbox"/>
Lifting heavy metal onto machinery	<input type="checkbox"/>
Moving heavy materials or other products from station to station manually	<input type="checkbox"/>

REDUCED RISK

- Use trolleys to transport raw materials and manufactured products throughout the production process.



Trolleys used to transfer steel to the next workstation.

PREFERRED SOLUTION

- Use electric walkie stackers to retrieve metal from racks and move bulk material through the workplace.



An electric walkie stacker.

- Use mechanical aids, e.g. overhead cranes, vacuum lifters and magnetic lifters to reduce the need for materials to be moved manually.

REDUCED RISK



Trolleys used for transporting materials.

- Use of pallet jacks to transfer product in stillages to the next workstation.



Pallet jacks assist in movement of product throughout the shop floor.

- Use dollies to move product to dispatch area.



Dollies move fabricated metals products to dispatch.

PREFERRED SOLUTION



Vacuum lifter used to transfer material to machine table.



A magnetic lifter is used to transfer product off machinery.



A manipulator is used to transport product to another workstation.

- Use electric pallet movers to move product through the workplace.

Refer to *A guide to handling large, bulky or awkward items* for trolley design guidelines.

MANUAL HANDLING



MANUFACTURING AT WORKSTATIONS

Manufacturing product at workstations can see employees stamping, pressing, assembling and drilling components. Risks are commonly associated with the layout of the workstation and the way the work is orientated.

It can also involve the use of high force and sudden or unexpected forces, as items may be heavy, can move unexpectedly and need to be manipulated and held in certain positions.

Does the task involve the following?

HIGH RISK	TICK
Working on/over metal that is lying on the floor	<input type="checkbox"/>
Lifting metal product on and off a work bench with high force	<input type="checkbox"/>
Working in awkward postures above shoulder height	<input type="checkbox"/>
Awkward postures when applying high force to push, pull or restrain metal products	<input type="checkbox"/>

REDUCED RISK

- Use mechanical aids.



Pallet lifters raise products to best working zone.

PREFERRED SOLUTION

- Automate the task.



This robot takes punched sheet metal and stacks it onto a pallet.

- Use adjustable height scissor lift workbench enabling the operator to work without bending excessively.

REDUCED RISK



Tables enable product being loaded into the machine to be kept between knee and shoulder height.

- Use well designed jigs, stands and other aids to hold items in the correct position so that work can be conducted within the best working zone.



This jig enables the worker to assemble the frame in the best working zone.

- Design workstations so that materials are reachable without twisting the back, working above the shoulder or overreaching.



This workstation keeps the materials in the best working zone for the worker.

PREFERRED SOLUTION



Hydraulic pallet lift table used as a workbench.

- Use powered rotators or other devices to present items so work is conducted in the best working zone.

MANUAL HANDLING



DIE HANDLING

Die handling includes a range of tasks, such as setting, moving and maintaining dies that are often very heavy. As such, die handling may be performed while in awkward postures and for long periods, increasing the risk of MSD.

Does the task involve the following?

HIGH RISK	TICK
Manual handling heavy dies	<input type="checkbox"/>
Loading/unloading die into machine manually	<input type="checkbox"/>
Manual tensioning in awkward postures	<input type="checkbox"/>
Awkward postures when setting die	<input type="checkbox"/>
REDUCED RISK	PREFERRED SOLUTION

Transporting dies

- Use manually operated lifting aids to transport heavy dies over hard, flat and even surfaces.
- Use ergonomically designed well-maintained trolleys or roller racks and roller trolleys to move dies/tools over hard, flat, and even surfaces.

- Use powered mechanical lifting aids such as mobile plant, overhead crane, hoist or manipulator to transport and position dies.



An electric walkie stacker

- Use or add winching/lifting points on dies/tools to enable use of mechanical aids to transport and position dies.

REDUCED RISK

PREFERRED SOLUTION

Loading and positioning dies

- Use die/tool positioning guides when loading/unloading into machine.



Press with die/tool positioning guides.

- Use hand tools that provide a large lever when manually tensioning.
- Use power tools to minimise the duration of awkward postures when securing dies in position.
- Use extension sockets for tools.
- Use detached tool holder set up.

- Introduce automated load/unload.
- Use self locating dies/tools in conjunction with mechanical aids when loading/unloading into machine.



Self-locating dies.

- Use powered tools for tensioning.
- Design out the need for awkward postures by:
 - providing easy access to connect auxillary services, e.g. pneumatics, etc.
 - locating controls and levers within easy reach
 - locating manual in-feed and out-feed points at waist level
- Introduce rotating self-loading jigs.
- Use mechanical aids, such as work platforms, to allow better access.

MANUAL HANDLING



PACKING STILLAGES

Stillages are often used for transporting product. Many have high solid sides that require the employee to fully bend. To reduce risk, removable sides or those that drop down, in combination with pallet lifters and tilted sides are useful.

Does the task involve the following?

HIGH RISK	TICK
Packing parts into stillages at floor level	<input type="checkbox"/>
Packing parts into stillages that have high sides	<input type="checkbox"/>
Manually packing heavy parts	<input type="checkbox"/>
Packing components that then entwine in stillage sides	<input type="checkbox"/>
REDUCED RISK	PREFERRED SOLUTION

Packing parts

- Use manually height-adjustable pallet/stillage lifters for stillages and components to eliminate bending to floor level to pick up component and to pack component into stillage
- Use stands to raise the height of the stillage to between knee and shoulder height with drop down/fold down or removable sides.



This stillage has been raised so it is between knee and shoulder height.

- Fully automate (robotics) packing the stillages.
- Use conveyors set within the best working zone for packing components into pallets/stillages.
- Use auto height adjustable pallet/stillages lifter with drop down/fold down or removable sides of pallet/stillage.



This stillage with drop down sides is on a scissor lift to raise the product to a good working height.

REDUCED RISK



Drop down side improves access for the worker.

- A bin insert, scissor insert or false bottom can help keep the product at waist level, while a tilt rig can allow better access.



This stillage is tilted for easier access.

PREFERRED SOLUTION

- Use mechanical aids to handle heavier components, e.g. cranes, hoists, etc.



Mechanical aids can be designed to handle specific parts.

MANUAL HANDLING

REDUCED RISK

- Use cardboard or timber liners to stop components entangling in sides.
- Ensure appropriate maintenance procedures are implemented to tag, remove from use, and repair damaged stillages.

PREFERRED SOLUTION

Stilling design and maintenance

- Alter stillage design so that components cannot entangle in sides.



Change from mesh to full panel sides

- Design stillage to assist in loading and securing of the product, e.g. stillage features material racking.
- Implement a preventative maintenance program to ensure drop/fold or removable sides are easy to handle and are free of damaged or faulty components.



LOADING AND HANDLING FINISHED PRODUCTS

Finished fabricated metal products are transported from the manufacturing site to customers by truck. A variety of different sizes and weights must be loaded for distribution.

Lifting metal items or pushing and pulling heavy loads involves the use of high force and sudden or unexpected forces especially if the items suddenly fall.

Does the task involve the following?

HIGH RISK		TICK
Large weights of finished product being moved manually		<input type="checkbox"/>
Loading of trucks with fabricated product that is not slung properly		<input type="checkbox"/>
Palletising product in awkward postures		<input type="checkbox"/>
REDUCED RISK	PREFERRED SOLUTION	

Palletising

- Use mechanical aids such as pallet lifters with turntables or pallet stands when palletising.

- Use vacuum lifters to palletise finished product.



Vacuum lift is used to palletise finished product.

- Use industrial robots for automation of the palletising operation.

MANUAL HANDLING

REDUCED RISK

- Raise load using hydraulic tailgate lifter.



- Loading dock at truck deck height allows mechanical aids to load onto vehicles.



Finished products can be loaded directly onto vehicles

PREFERRED SOLUTION

Loading trucks

- Use forklifts.
- Use cranes.



A purpose built vehicle assists in loading materials.



Overhead cranes assist in the loading of finished products

2

HAND TOOL USAGE

ANGLE GRINDING

WELDING

HAND TOOL USAGE

Hand tools

'Hand tools' refers to 'a tool used with a person's hands', these include:

- tools designed for force to be applied by the person, such as screwdrivers, hammers, chisels, and hacksaws, and
- tools where force is applied by a power source, but a person is still needed to hold the tool, such as portable electric or battery drills, grinders, saws or pneumatic impulse tools, spray guns or nail guns, etc.

Hand tools are used in static workplaces, such as a workshop, and in an environment external to the workshop, like a construction site or an installation on a client's site. MSD risks from hand tool usage mainly result from:

Task design – frequency, duration, speed of tool usage

Tool design – weight, shape, fit to user, vibration, recoil, shock loading

Workstation design – size, shape and layout

Tool maintenance – poorly maintained tools may compromise safety and increase the effort required to use them

External/construction job design – jobs can be poorly engineered and designed with no consideration of the process that will be required for installation.

Poor hand tool design and excessive use of hand tools are associated with chronic disorders of the hand, wrist and forearm, such as carpal tunnel syndrome and wrist tendonitis.

Major factors affecting the potential for injury include:

- **Muscular effort** in using tools (holding, operating and guiding) because of poor handle design, or heavy, poorly balanced and/or poorly maintained tools
- **Static loading** of arm and shoulder muscles from holding tools can lead to fatigue when maintained for prolonged periods and eventually to injury
- **Awkward wrist positions** such as holding tools with the wrist bent up, down or sideways causes additional muscular effort in using tools
- **Contact pressure** on tissues or joints, from tools pressing into the palm at the base of the thumb where blood vessels and nerves pass through the hand contributes to the development of carpal tunnel syndrome
- **Wide grip span** can cause tendon injury known as 'trigger finger'. The risk is increased when force is exerted at the limits of the grip span.

Hand tool selection

Well maintained tools matched for the person and the task, used infrequently at well designed workstations, do not cause harm. When the tool does not match the person or the task or is used repeatedly and/or for long periods that hand tool and work area design become critical.

The best hand tool to select is one that:

- matches the task that the user is doing
- fits the workspace available
- reduces the force the user needs to apply
- fits the users hand
- can be used in a comfortable position, and
- is well maintained.

Fit the tool to the person, not the person to the tool



ANGLE GRINDING

Grinding is a major cause of injury in the metal fabrication industry. Serious injuries range from foreign materials in the eye to injuries due to kick back from the grinder as well as deafness related to noisy grinders or processes.

In addition, prolonged or repeated exposure to hand/arm vibration and repetitive or sustained hand/arm postures can lead to MSD.

Does the task involve the following?

HIGH RISK	TICK
Excessive vibration while grinding	<input type="checkbox"/>
Exerting force while in an awkward posture	<input type="checkbox"/>
People other than person grinding exposed to dust and particulates	<input type="checkbox"/>
Kick back from grinders	<input type="checkbox"/>
Grinding without guarding	<input type="checkbox"/>
Excessive noise	<input type="checkbox"/>

REDUCED RISK	PREFERRED SOLUTION
--------------	--------------------

Task

<ul style="list-style-type: none"> • Improve the welding process to minimise grinding. 	<ul style="list-style-type: none"> • Assess whether grinding is required at all. • Consultation with the client can help achieve this.
---	--

HAND TOOL USAGE

REDUCED RISK

- Raise the work task by using an adjustable workstation for the task.



- Ensure work pieces/objects are secure.
- Use well maintained screens to separate the task of grinding from other workers.
- Curtains and screens need to meet AS 3957.

PREFERRED SOLUTION

Workstation

- Use an adjustable jig rotator or fixture to move and align the part that allows the person to undertake work in an upright position within the best working zone.
- Use the most appropriate tool to minimise hand/arm vibration and extreme hand, arm or wrist postures.
- Use booths to separate grinding from other workers.

Eye Protection

- Safety glasses.

- Goggles or safety glasses and face shield.

Grinder Safety features

- Anti-kick back safety clutch.
- Soft start vibration reducing handle.
- Re-start protection.
- Grinder fitted with braking system to rapidly stop the wheel.**
- Noise reduction grinding disk.

Other considerations

Ensure that:

- the correct type of disc is being used
- the guard and handles are secure
- the correct flange and locking nut is in place for the type of disk being used
- there are no defects or damage to the disc

**Technology available is a brake system from 280km/hr to 0 in 2.5 seconds.

Further information on personal protective equipment and noise can be obtained in the “Environment” section of this document



WELDING

During the welding process health and safety hazards may take the form of metal fumes, radiation, hot metals and noise. General ventilation and personal protective equipment all serve to protect the worker from the hazard. However further control measures are often required.

Welding often sees metal items and welding tools being lifted, lowered, pushed, pulled or restrained and can involve the use of high force and sudden or unexpected forces, as the items can be heavy, move unexpectedly and need to be manipulated and held into certain positions.

Does the task involve the following?

HIGH RISK	TICK
Welding in confined areas without ventilation	<input type="checkbox"/>
Welding in awkward postures	<input type="checkbox"/>
Welder exposed to flash	<input type="checkbox"/>
Exposure to gases such as ozone, carbon monoxide and toxic substances	<input type="checkbox"/>
Excessive noise	<input type="checkbox"/>
People other than welder exposed to flash	<input type="checkbox"/>

REDUCED RISK	PREFERRED SOLUTION
---------------------	---------------------------

Fumes

- Use a standard respirator – negative pressure.



- Fixed or portable extraction system



Fixed extraction unit assists in removing exposure to fumes, the unit is manoeuvrable to ensure fumes are taken away from the welder at all times.

HAND TOOL USAGE

REDUCED RISK

- Ensure the area is well ventilated, portable fans can be used to disperse and dilute fumes in a workplace that has a large work area with ceiling extraction.

PREFERRED SOLUTION

Fumes

- PPE (PAPR – Positive air powered respirator)



PAPR Style respirator and welding mask.
Air supplied respirators.

Arc exposure

- Use a flip visor.



Flip visor must meet Australian Standard 1338:1:1992

- Use auto darkening helmets.



Auto darkening helmets must meet Australian Standard 1338:1:1992

REDUCED RISK

PREFERRED SOLUTION

Workstation layout

- Use well maintained screens to separate the task of welding from other workers.
- Curtains and screens need to meet AS 3957.



- Standard operating procedures can also be used to approach the task of welding in a safe manner. These procedures can be developed by the employer in consultation with HSRs and workers.
- Raise the work task by using an adjustable workstation for the task.



This adjustable stand helps keep the task within the best working zone.

- Use welding booths to separate welding from other workers
- Have a permit system (if applicable) such as a hot work permit to ensure work is done safely
- Provide equipment on counterbalances



Welding equipment on counterbalances.

- Use an adjustable jig rotator or fixture to move and align the part.



Rotating jigs handle and align the parts being welded.

HAND TOOL USAGE

REDUCED RISK

PREFERRED SOLUTION

Workstation layout



- Cable gantries prevent snagging of cables, tripping hazards and manual handling effort due to cable weight.



- Cylinders near, but not within, work area and secured.

- Cylinders secured to prevent tip over and located away from work area in a safe position.

Further information on personal protective equipment and noise can be obtained in the “Environment” section of this document

3

GUARDING

POWER PRESSES
BRAKE PRESSES
GUILLOTINES

GUARDING

There are various systems available to guard dangerous parts of machinery to prevent bodily access. If guarding is to be used as a control measure, the employer is required to ensure any guard designed for the plant will, so far as is practicable, prevent any access to the danger point or area of the plant.

Guarding to be installed onto plant should be designed and installed, inspected and removed for maintenance purposes only by a suitably qualified and competent person. In many instances, the guarding is designed and installed by an electrical contractor who is not familiar with the current Australian Standard *AS4024.1201 – 2006, Safety of Machinery, Part 1201: General Principles – Basic terminology and methodology*.

The plant guarding hierarchy is as follows:

1. Permanently fixed physical barrier
2. Interlocked physical barrier
3. Physical barrier
4. Presence sensing system



1. Permanently fixed physical barrier

Permanently fixed physical barriers are normally used when there is no requirement for access during operation, maintenance or cleaning of the plant.



2. Interlocked physical barrier

An interlock guard is one that is moveable or has a moveable part. The movement of the guard interacts with the hazardous parts of the plant or the control system of the plant to prevent motion of the hazardous parts while the guard is open. The interlocking system must be designed so that it cannot be overridden or disabled and will shut down the plant should tampering with the system occur.



3. Physical barrier

A guard having no moving parts that prevents access to the dangerous part of the machinery and that offers protection while the guard is in its intended position. The physical barrier can only be altered or removed by a suitably qualified and competent person using a specialist tool.



4. Presence sensing system

These guards consist of an intangible barrier created by photoelectric or similar devices capable of electronically detecting intrusion into the hazardous area of a machine.

Note: Operators of metal working machinery need to be trained and competent in the use of metal machinery.

POWER PRESSES

Adequate guards must be provided. Many power press incidents are due to reliance on the operator to synchronise the movement of their hand with the operation of the foot pedal. No amount of experience can prevent this type of incident from occurring.

Furthermore, two-handed controls implemented without additional control measures are not an acceptable means of protection. They offer no protection to assistants or bystanders, and are easily defeated.

Power presses should be adequately guarded and designed in accordance with Australian Standard 1219-1994 *Power presses safety requirements*.

To prevent body parts entering the danger zone, one or more of the following measures (listed in priority order) should be taken:

1. Plant should be designed to prevent access to any dangerous parts such as limiting the press stroke, or designing the die or stripper, so that the maximum clearance between moving parts does not exceed 6mm
2. Guards should be fixed to prevent access to any dangerous parts
3. Automatic material feeders should be provided, or
4. Interlocking guards to prevent operation unless the guard is closed and secured.

Emergency stops must be easily accessible at all points of the press where an operator is, or may be, required to be in the operation of the plant.

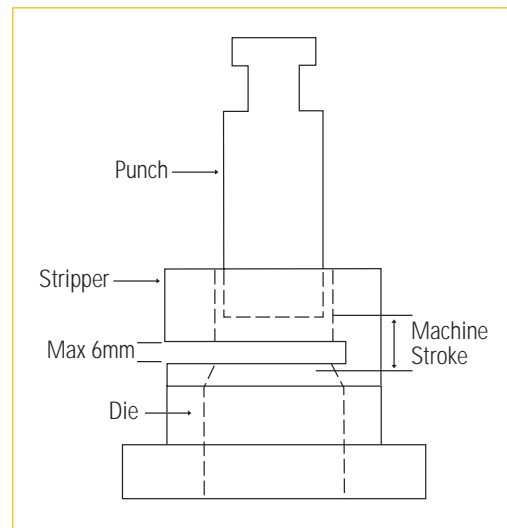

Other things to consider include:

- Guarding may need to be designed to ensure a good view of the tool area and prevent access from all sides, including the rear, not just the operating position. Guarding designs should address operation, maintenance/inspection and cleaning of equipment
- If guarding requires adjustment for particular dies/objects, an appropriate guarding position or configuration should be nominated. These should be recorded and controlled mechanically where possible, and
- Other dangerous moving parts, such as the flywheel, gears or shafts also must be guarded.

BRAKE PRESSES

Press brakes are generally used to bend a work piece, normally thin gauge sheet metal placed between upper and lower dies, through the force and pressure exerted by a lowering ram. A press brake is a specialised type of press consisting of a long, narrow ram and bed. Press brakes come in a variety of sizes and capabilities, ranging from hand-operated units to machines with a capacity of 3,000 tonne or more.

Conventional press brakes operate in a downward motion during the power stroke to force the upper ram and attached bending die down onto a lower die attached to a stationary bed. The profile of the upper and lower die, the length of stroke, and gauge and properties of the feed material determine the finished profile.

Where mechanical guarding is employed on a brake press, the guard is normally interlocked with the process that initiates the stroke and prevents access to the nip points of the die prior to the ram stroke commencing.

When fitting a mechanical guard in front of the dies could interfere with the metal forming process the press brake is normally fitted with a light curtain and/or pressure mat, or is fully guarded by an interlocked fence and gate, with the feed material being placed into the brake press using a robotic feed mechanism.

GUARDING

METAL CUTTING GUILLOTINES

The most common metal guillotine injuries are crushed or amputated fingers. Incidents that result in these injuries are often caused by the clamps that hold the metal being cut and not the blade or fingers being jammed under the sheet of metal being cut.

Guarding of the guillotine must prevent a person's fingers, hands or other body parts entering the trapping space during the working or return stroke, and from accessing the blade.

Front guards

For most purposes and especially for the shearing of flat metal sheet, a **fixed guard** at the front of the machine should always be used. The guarding should ideally be slotted so that the operator can see the material being cut and task lights should also be positioned on the guard to illuminate the cutting area. The guard can be adjusted to allow for materials of varying thicknesses to be cut. The positions of an adjustable guard should be nominated as appropriate and documented for operator training. These settings should be listed on the machine and guard. Alternatively, the guarding should be designed to remain in the appropriate position based on the thickness of the material being worked on.

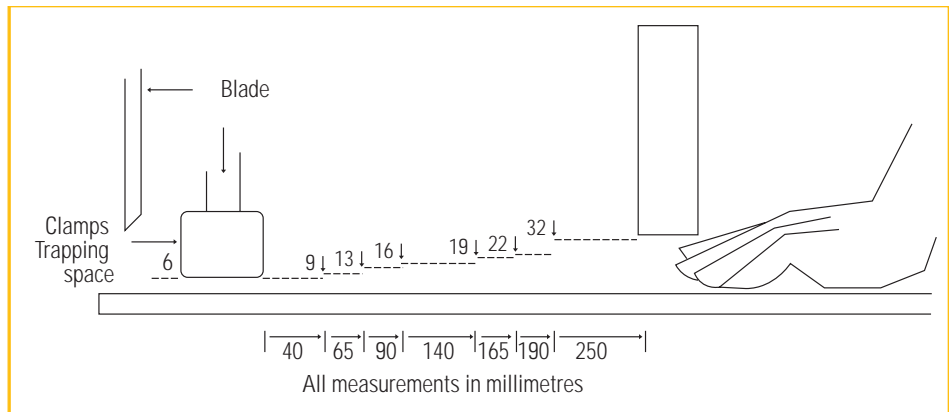

When a fixed guard is not possible, because heavy plate is to be sheared on large guillotines, this issue may be overcome if the machine is operated through use of a friction clutch, by the use of a moveable hinged guard interlocked with the machine controls.

Rear guards

Guarding such as a physical barrier of sufficiently spaced steel tubing and/or steel mesh should be fitted to prevent people from reaching the blade at the rear of the machine. A chute can be incorporated to allow off cuts to be retrieved.

Throat guards

The openings of each side of the guillotine are also danger areas that present a risk of bodily access to the blade when slitting metal sheets wider than the machine table. Slotted end guards should be fitted to allow the cutting of long or wide metal sheet.

Other safeguards

Guarding of flywheels, belts, pulleys, shafts and other parts should also be provided.

4

ENVIRONMENT

PLANT LAYOUT

WORKPLACE TRAFFIC MANAGEMENT

NOISE

HOUSEKEEPING

TEMPERATURE

PROTECTIVE CLOTHING AND EQUIPMENT

The environment of the workplace can affect the overall health and safety of all employees. Plant layout and other physical situations need to be considered to ensure workers are not placed at risk.

PLANT LAYOUT

The layout of plant should always be considered from a health and safety perspective as well as from a production perspective.

The following matters should always be considered:

- the location of designated raw material and delivery areas
- that raw materials are stored in an easily accessible area close to the start of the production area
- lineal workflow through the production line
- clear areas of work
- reduction of blind spots throughout the plant, and
- traffic management and designated forklift and pedestrian segregation.

WORKPLACE TRAFFIC MANAGEMENT

A documented Traffic Management Plan is an invaluable aid to resolving many hazards and issues associated with forklift operations and heavy vehicle movements. The plan should be based on an assessment of forklift hazards and issues. It will govern all activities and procedures relating to forklift operations, and should cover areas such as:

- seat belts
- pedestrian exclusion zones
- blind spots
- loading and unloading
- right of way
- policy development
- maintenance
- incident reporting and investigation
- site layout
- designated traffic zones
- use of attachments
- signage
- purchasing
- training.

Involving health and safety representatives and other employees, particularly forklift operators, is an essential part of this process, resulting in many ideas, and possible solutions being put forward.

The Traffic Management Plan should be regularly reviewed and updated when workplace changes or equipment upgrades occur.

Any Traffic Management Plan must address the issue of pedestrian exclusion zones and other ways to eliminate or minimise pedestrians in the same area as working forklifts.

Refer to *Forklift safety. Reducing the risk-forklift instability* for further information.

NOISE

In the metal product manufacturing industry, numerous items of plant and various activities such as grinding, hammering steel, guillotining, cutting metal, pressing and even disposing of metal objects in bins can produce noise that can be damaging.

If employees in your workplace are exposed to noise that exceeds the exposure standard of 85 dB(A) averaged over an eight hour period or a peak noise level of 140 dB(c) then your workplace is too noisy and one or more of the controls must be implemented to ensure employee noise exposure does not exceed the standard.

Furthermore if any of the following occurs, noise controls are likely to be required:

- employees have to raise their voice to communicate at a distance of one metre, or
- employees have a temporary reduction in hearing or ringing in the ears after leaving work for the day.

The noise regulations set out a hierarchy of controls to be applied when fixing noise hazards. These are:

1. Elimination of noise sources
2. Substitution of quieter plant or processes, or use of engineering measures
3. Administrative measures, and
4. Hearing protectors.

Hearing tests must be provided where hearing protectors are required to make sure that employees' exposure does not exceed the noise standard.

It is worth noting that if there are changes to the workplace, like a new machine coming in or more machines being compressed into a smaller area then it may be necessary to redo noise level tests.

Refer to the *Occupational Health and Safety Noise Regulations* for further information.

ENVIRONMENT



Clear walkways avoid trips and falls.

HOUSEKEEPING

Poor housekeeping can result in an increased risk of injury and a decrease in work efficiency.

By implementing a good housekeeping plan, areas are kept clean and free of waste and the risk of injuries occurring due to slip, trips and falls, together with injuries resulting from hitting stationary objects, are reduced.

Items should be stored correctly with no parts protruding onto walkways. Electrical cords should not be on the floor, tools should have designated areas for storage and bins for waste should be readily available and be easy to empty.

Structured programs that focus on organisation, cleanliness and standardisation can be introduced to the workplace to assist with this. Cleanliness can be maintained in a 'clean as you go' manner or the need for constant housekeeping can be eliminated from the source e.g. leaks, etc.



Designated areas for parts keep the workplace tidy



Readily available bin disposal with crane attachment for ease of emptying

LIGHTING

The quality of lighting in a workplace has a significant effect on safety and productivity. Good lighting in the workplace promotes:

- a reduced risk of injuries through better visibility
- a reduced risk of short and long term health problems such as headaches and eye strain and vision impairment loss, and
- a brighter, cleaner workplace resulting in a more active, cheerful environment.

This can be achieved by:

- making full use of natural light by installing windows and skylights
- ensuring overhead and fixed lighting is at appropriate levels and is appropriately maintained and replaced
- using task lighting with a flexible arm to enable light to be directed to the spot where light is needed
- painting ceilings and walls a lighter colour allowing more light to be reflected and assisting in increasing the light within the workplace.

Refer to *Australian Standards AS 1680* for more information on lighting in the workplace.

TEMPERATURE OF WORKPLACE

Under the OHS Act, employers have a responsibility to provide a safe and healthy workplace. This broad duty of care includes ensuring workers are not subjected to excessive heat or cold that may cause illness. Heat illness covers a range of medical conditions that can arise when the body is unable to properly cope with working in the heat. Signs and symptoms of heat illness include nausea, dizziness, weakness, clumsiness, collapse and convulsions. Employees exhibiting these symptoms should seek immediate first-aid/medical attention.

Some conditions are:

- heat stroke – a life threatening condition that requires immediate first aid and medical attention
- fainting in heat (heat syncope)
- heat exhaustion
- heat cramps
- heat fatigue.

As with any other occupational health and safety risk, there are general procedures to follow when assessing the risk of heat at work. These include consulting the employees who are exposed to the heat as well as their health and safety representatives. In consultation with your employees a Heat Alert Program should be considered as it is the best way to minimise the risk of heat illness.

For indoor work

- air conditioning/air circulation fans/good ventilation
- insulation of roof and wall insulation or shielding of sources of heat and external ducting of hot exhausts.

For outdoor work

- suitable protective clothing with ventilation, sunburn creams and skin protector, air-conditioned vehicles and rest areas.

In addition, ensure employees have access to adequate supplies of cool drinking water. Allocated breaks should also be made available as determined by the conditions, preferably providing shade during their breaks.

PROTECTIVE CLOTHING AND EQUIPMENT

Protective clothing and equipment is a common risk control for employees exposed to chemicals, fumes, vapours or dusts. However, it is not a good idea to rely on protective clothing and equipment to control risk as it may not properly protect all employees from risks and can create new risks and work problems.

As far as reasonably practicable, controls other than the use of protective clothing and equipment should be used to manage risks arising from the use of chemicals, fumes, vapours or dusts.

Personal protective clothing and equipment should be seen as a temporary measure or a last resort to be used only when other controls may not adequately control exposure, or are not reasonably practicable.

Risks of using protective clothing and equipment

- does not eliminate or reduce the risks and dangers
- may not be cost effective - often the long term monetary and employee time costs of using protective clothing and equipment are not taken into account. This includes the costs of:
 - selection
 - storage
 - cleaning
 - fitting
 - medical examinations required before use
 - purchase
 - replacement
 - maintenance
 - training employees in use and maintenance
 - monitoring of use and extra supervision.
- only provides limited protection
- will not protect employees if it is not properly selected, fitted, used, maintained and stored
- is often less effective if more than one type of personal protective clothing and equipment is used at the same time
- is not always used when it should because it
 - interferes with doing the job
 - causes discomfort and/or pain
 - affects vision, e.g. safety goggles, full face respirators
 - interferes with hearing and talking e.g. hearing protection, respirators
 - is not used by some employees for health, physical and psychological reasons
 - is difficult to use correctly if not properly supervised, and
 - interferes with employee concentration.

Protective clothing and equipment can increase manual handling risks by:

- increasing heat stress in hot work areas as this makes the work harder and increases tiredness and the risk of heat illness
- restricting postures and movements as this can make the job harder to do and increases the chances that protective clothing and equipment won't be properly used e.g. gloves can prevent getting a good grip on tools, components and materials - this puts more physical stress on the hands, arms and shoulders;
- using non-powered respirators that can make breathing harder, worsened if the filters need changing, making the job harder to do, and
- restricting movement and mobility if air-lines and air-hoses are used with air supplied respirators as this can make the job harder to do and creates tripping risks.

For further information on the selection of appropriate Personal Protective Equipment, please refer to the *Safe Manual Handling of Chemicals in the Automotive Industry* for a seven step selection guide (pgs 36 – 41).

OTHER USEFUL GUIDANCE MATERIAL

The fabricated metal industry may also be interested in publications developed for other industries including:

- *A Guide to Handling Large, Bulky and Awkward Items*
- *A Guide to Manual Order Picking*
- *Manual Handling in the Automotive Industry*
- *Manual Handling in the Sawmilling Industry*
- *Manual Handling in the Textile Industry*
- *Delivering Large Gas Cylinders – A Guide to Manual Handling*
- *A Guide to Preventing Injury from Packing and Unpacking Shipping Containers and Enclosed Trailers*
- *Slips, Trips and Falls in the Retail Industry Checklist*
- *WorkSafe Guide for Assessing and Fixing Noise Problems at Work*
- *WorkSafe Guidance Note on Respiratory protective devices*
- *WorkSafe Guidance Note: Spraying flammable liquids-paints lacquers, adhesives, resins*
- *WorkSafe publication: Working in the Heat*
- *Australian Standard AS 4024.1-2006, Safety of Machinery*
- *Australian Standard AS 1715 – Selection, use and maintenance of respiratory protective devices*
- *Australian Standard AS 4114 – Spray Painting Booth*
- *Australian Standard AS 1716 – Respiratory protective devices*
- *Australian Standard 1647-1980 – Fire Precautions in Cutting, Heating and Welding Operations*
- *Australian Standard 4839-2001 – The safe use of portable and mobile oxy/fuel gas systems for welding, cutting, heating & allied processes.*
- *Australian Standard 1788.1-1987 – Abrasive Wheels – Design, Construction and Safeguarding*
- *Australian Standard 4991-2004 Lifting Devices*
- *Australian Standard 2549 – Cranes (including hoists & winches) – Glossary of terms*
- *Australian Standard 1418.1-1997 – Bridge, gantry, portal & jib cranes*
- *Australian Standard 1219-1994 – Power presses – Safety requirements*
- *Australian Standard 1893-1977 – Code of practice for the guarding & safe use of metal & paper cutting guillotines*

ACKNOWLEDGEMENTS

WorkSafe Victoria would like to acknowledge the following contributors to this publication:

Fabricated Metals OHS Working Party
Australian Industry Group
Australian Manufacturing Workers Union
National Union of Workers
Workcover NSW
Department of Industrial Relations QLD
Australian Steel Institute
Structural Steel Fabricators Association
Victorian Employers Chamber of Commerce & Industry
Australian Workers Union

Thanks also to all the workplaces who participated in the *Fabricated Metals Solutions Workshop* in September 2006 in order to write this publication

Workplaces and suppliers

John Beaver
Marshall & Nicholls
Planex
Schiavello
Skrobar Structural Steel
One Steel
Diver Consolidated Industries
Steel Frame Solutions
Scott Safety
Just Tools

WORKSAFE VICTORIA

Advisory Service

222 Exhibition Street
Melbourne 3000

Phone 03 9641 1444
Toll-free 1800 136 089
Email info@workcover.vic.gov.au

Head Office

222 Exhibition Street
Melbourne 3000

Phone 03 9641 1555
Website . . . www.workcover.vic.gov.au

Local Offices

Ballarat 03 5338 4444
Bendigo 03 5443 8866
Dandenong 03 8792 9000
Geelong 03 5226 1200
Melbourne
(628 Bourke Street) 03 9941 0558
Mildura 03 5021 4001
Mulgrave 03 9565 9444
Preston 03 9485 4555
Shepparton 03 5831 8260
Traralgon 03 5174 8900
Wangaratta 03 5721 8588
Warrnambool 03 5564 3200